

**LAKWOOD INSTRUMENTS
MODEL 2830e**

**MICROPROCESSOR-BASED
ORP AND CONDUCTIVITY CONTROLLER**

INSTALLATION & OPERATION MANUAL

SERIAL #: _____



Lakewood Instruments

7838 North Faulkner Road, Milwaukee, Wisconsin 53224 USA

Phone (800) 228-0839 • Fax (414) 355-3508

<http://www.lakewoodinstruments.com>

Lakewood Instruments™ Model 2830e Controller

Quick Installation Sheet

1. Attach the four (4) supplied mounting feet to the back of the controller enclosure either vertically or horizontally. Install the controller on a flat, non-vibrating surface. Do not mount the controller to a steel object that has a large temperature change (side of cooling tower, etc). This can cause water to condense inside the enclosure.
2. Install water meters, chemical pumps, plumbing assemblies, ORP sensor, and the conductivity sensor (see drawing on back).
3. Install the provided strain reliefs with nuts, if necessary, by removing the attached black plugs and inserting strain relief through hole. Wire the flow switch, ORP sensor, conductivity sensor, water meters and 4-20 mA output; if applicable (see drawing on back). Ensure wiring connections are correct or damage may occur.
4. If doing a conduit installation, remove receptacles and wire pumps and bleed valve directly to the terminals. If using a motorized ball valve, wire as per wiring instructions. Refer to the instruction manual for more details.
5. Plug in chemical pumps and valves to controller (unless hardwired as per step #4).
6. Apply power to the model 2830e controller, press "**CLR**" twice, press "**7**" System setup, press "**2**" Initialization, press "**2**" Whole controller, press "**1**" Yes. After initialization, press the "**CLR**" key several times until you get to the main menu.
7. Press "**1**" Process, Press "**ENT**". This screen allows manual control of the relay outputs to test the chemical pumps and valves. Press "**CLR**" to return to the Process screen.
8. Calibrate the ORP and conductivity. Take a sample with a handheld meter, press the "**PRO**" button, select ORP or Conductivity and type in the ORP or conductivity value, press "**ENT**". See instruction manual for more details.
9. Program the model 2830e relays for chemical feed schemes. See instruction manual for more details.

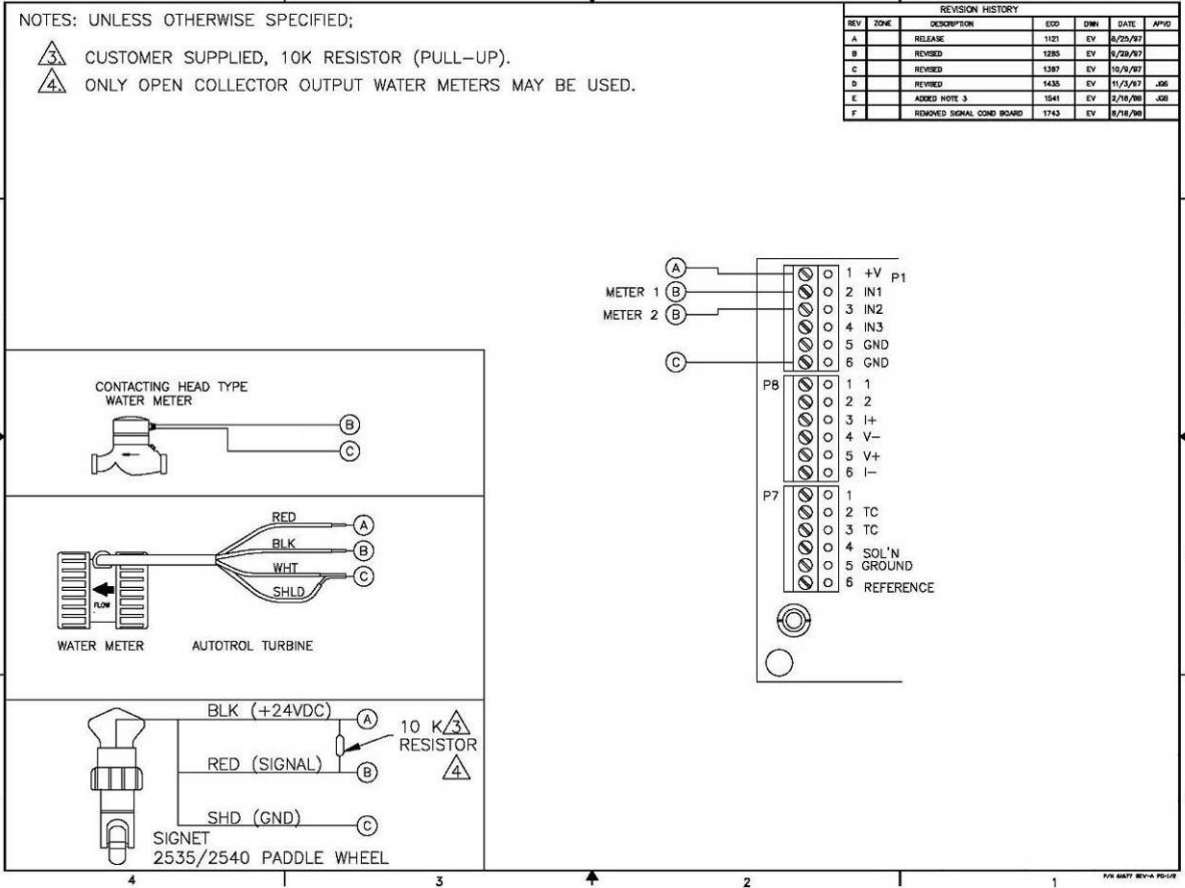
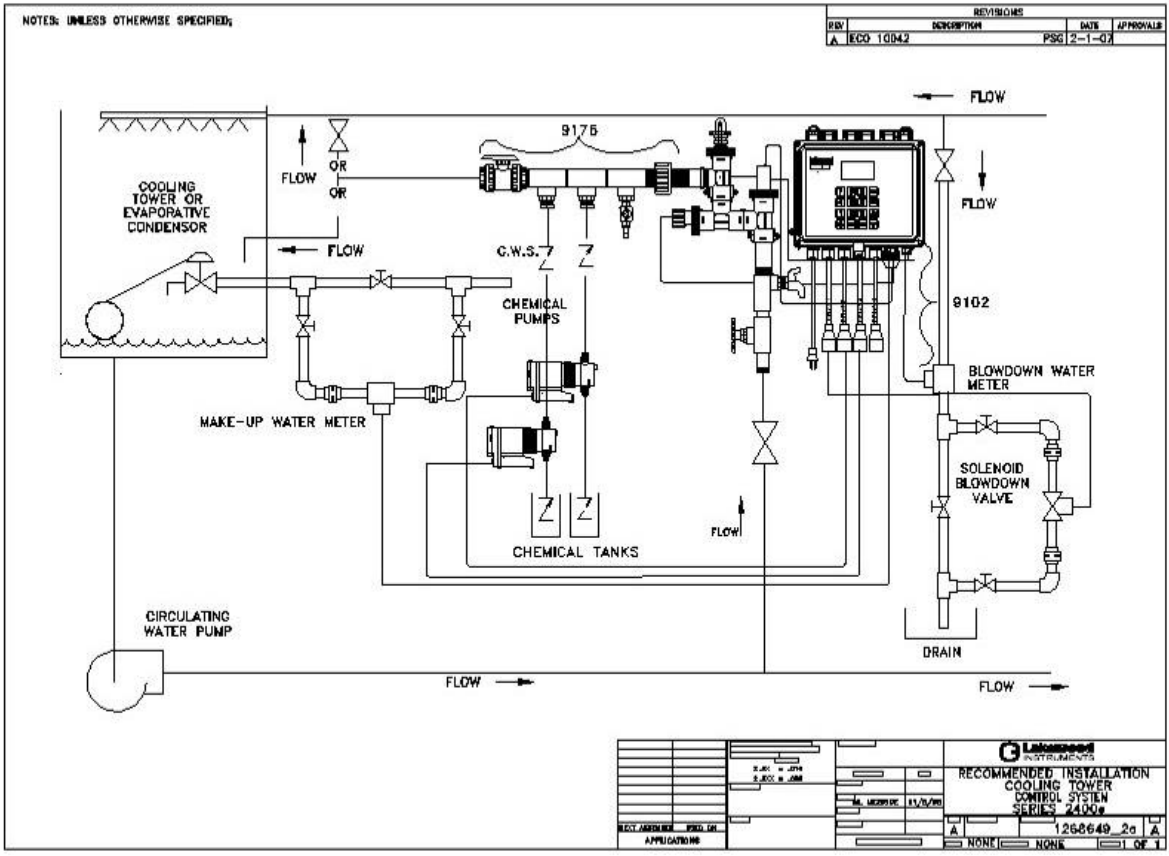

FIGURE A

IMPORTANT NOTICE

WARNING: CHEMICAL FEED

All electromechanical devices are subject to failure from a variety of causes. These include mechanical stress, component degradation, electromagnetic fields, mishandling, improper setup, ORPhysical abuse, chemical abuse, improper installation, improper power feeds, and exposure.

While every precaution is taken to insure proper functioning, extra precautions should be taken to limit the ability of over-feeding by limiting chemical quantities available, secondary shut-downs, alarms, and redundancy or other available methods.

CAUTION: POWER SOURCE AND WIRING

Low voltage wiring and high voltage (110 plus) should not be run in the same conduit. Always run separately. Even shielded low voltage is not a guarantee of isolation.

Every precaution should be taken to insure proper grounding and elimination of shorting or Electromagnetic field (EMF) interference.

WARNING: ELECTRICAL SHOCK

To reduce the risk of electrical shock, this equipment has a grounding-type plug that has a third (grounding) pin. This plug will only fit into a grounding-type outlet. If the plug does not fit into the outlet, contact a qualified electrician to install the proper outlet. **DO NOT** change the plug in any way.

Lakewood Instruments

We thank you for your selection and purchase of a Lakewood Instruments product.

With proper care and maintenance, this device should give you many years of trouble-free service. Please take the time to read and understand this Installation and Operation Manual, paying special attention to the sections on **OPERATION** and **MAINTENANCE**.

If, in the future, any parts or repairs are required, we strongly recommend that only original replacement parts be used. Our Customer Service Department is happy to assist you with your parts or service requests.

 **Lakewood Instruments Customer Service and Technical Support Departments can be reached by calling (800) 228-0839 or faxing (414) 355-3508, Monday through Friday, 7:30 a.m. - 5:00 p.m. CST.**

 **Mail should be sent to:**

**Lakewood Instruments
7838 North Faulkner Road
Milwaukee, WI 53224 USA**

MODEL 2830e

Table of Contents

1.0 Introduction	8
2.0 Features, Benefits and Specifications	9
2.1 Features	10
2.2 Benefits	10
2.3 Specifications	11
2.4 Ordering Information.....	12
3.0 Unpacking, Mounting and Installation	13
3.1 Unpacking	13
3.2 Mounting the Enclosure.....	13
3.3 Plumbing Installation	14
3.3.1 Blowdown Valve Sizing.....	15
3.4 Electrical Installation	16
3.4.1 Incoming power 115/230 VAC	16
3.4.2 Relay Outputs	17
3.4.3 Flow Switch Wiring	17
3.4.4 Water Meter Wiring.....	18
3.4.5 4-20 mA Output Wiring	18
3.4.6 Node Wiring.....	18
4.0 Functional Overview.....	19
4.1 Display.....	19
4.2 Keypad	19
4.3 Menu	19
4.4 Security Levels	20
5.0 Starting Up the Controller.....	20
6.0 Operation of Controller	21
6.1 Process Screen	21
6.2 Manual Operation of the Relays.....	22
6.3 Calibration of Conductivity, ORP, and ORP	23
6.3.1 Calibration of Conductivity.....	23
6.3.2 Calibration Check of Conductivity in Buffer Solutions.....	23
6.3.3 Conductivity vs. ppm	24
6.3.4 Calibration of ORP.....	25
6.3.5 Single-Point Calibration	25
6.3.6 Two-Point Calibration	25
6.3.7 Calibration Check of ORP in Buffer Solutions	26
6.3.8 Calibration of ORP.....	26
6.3.9 Zero of Span?.....	27
6.3.10 Calibration Error Messages	27
6.3.11 Calibration Check of ORP in Buffer Solutions	27
6.4 Main Menu.....	28

6.5 Configuring the Relays	29
6.5.1 Configuring the Blowdown Relay	29
6.5.1.1 Disabled	30
6.5.1.2 By Tower Setpoint	30
6.5.1.2.1 Setpoint	30
6.5.1.2.2 Deadband	30
6.5.1.2.3 Blowdown Timeout	31
6.5.1.3 By Makeup Volume	31
6.5.1.4 Change My Name	32
6.5.1.5 Scheduled Lockout?	32
6.5.1.6 Blowdown By Cycle Setpoint	33
6.5.1.7 By Multi-Setpoint	34
6.5.2 Configuring Relays 2, 3, 4	35
6.5.2.1 Disabled	35
6.5.2.2 By Setpoint	35
6.5.2.2.1 Setpoint	36
6.5.2.2.2 Deadband	36
6.5.2.2.3 Overfeed Time	36
6.5.2.2.4 When to Activate	37
6.5.2.3 By Water Meter	37
6.5.2.4 By Percent of Blowdown	37
6.5.2.5 By Percent of Time	38
6.5.2.6 By Feed Schedule	39
6.5.2.7 As an Alarm Relay	39
6.5.2.8 Change My Name	40
6.5.2.9 Scheduled Lockout?	40
6.5.3 Setting up the Feed Schedule	41
6.5.4 Alarms	43
6.5.5 Water Meters	44
6.5.6 4-20 mA Outputs	45
6.5.6.1 Setup of the 4-20 mA Output	45
6.5.6.1.1 Set the 4-20 mA Range	46
6.5.6.1.2 Calibrate	46
6.5.6.1.3 Which Process?	46
6.5.6.1.4 Manual Control	47
6.5.6.1.5 Change My Name	47
6.5.7 The System Setup Menu	47
6.5.7.1 Process Parameters	47
6.5.7.2 Initialization	48
6.5.7.3 Digital Inputs	48
6.5.7.4 Firmware Versions	48
6.5.7.5 Change the Security Passwords	49
6.5.7.6 Diagnostics	49
6.5.7.7 Communications	49
6.5.7.7.1 Com Port Setup	50
6.5.7.7.2 Initialize Modem	50
6.5.7.7.3 Remote Password	51
6.5.7.8 Node Installation	51
6.5.8 Setting the Clock	51

6.5.9	Changing the Security Levels	52
7.0	Maintenance.....	53
7.1	Sensor Maintenance.....	53
7.1.1	Conductivity Sensor.....	53
7.1.2	ORP Sensor or ORP Sensor	53
7.2	Flow Switch Maintenance.....	54
7.2.1	Replacing The Reed Switch.....	55
7.3	Replacing the Fuse.....	55
8.0	Troubleshooting	56
8.1	Error Messages	56
9.0	Factory Service	59
10.0	Drawings	
10.1	Cooling tower Suggested installation	1269031-2a
10.2	Wiring Diagram, Sensor Wiring	1268628-2a
10.3	Wiring Diagram, ORP to NORP	1104522-5a
10.4	Wiring diagram for water meter inputs	1109544-2f
10.5	Electrical Schematic.....	1269031-3a
10.6	Wiring Diagram RS2L Option	1109706-1d
10.7	Wiring Diagram RS2L Option.....	1109706-6c
10.8	Wiring Diagram 4-20 mA output, 35L.....	1109707-1b
10.9	Wiring Diagram NIN Option.....	1167855-3a

1.0 INTRODUCTION

The Model 2830e is a LONWORKS Technology, microprocessor based, menu driven, ORP and conductivity water treatment controller with 8 relays designed for use in cooling towers. The Model 2830e provides for ORP and conductivity tracking and control, flow monitoring and chemical injection. The Model 2830e is NTL/CSA approved.

The Model 2830e uses the latest in microprocessor capability, giving the user a high level of application flexibility. A large illuminated graphics screen, multiple inputs, and an intuitive menu characterize this new technology.

Security features allow full access to programming features or restrict access to viewing only. An operator password can help ensure that only authorized personnel will operate the system.

The Model 2830e is user-friendly with a graphical screen and 16-key numeric keypad. It accepts multiple inputs and is easily configured. This controller can easily be upgraded in the field. It's a combination of reliability, accuracy, security and simplicity.

LONWORKS Technology gives you a high level of flexibility with the capability of adding nodes, additional inputs and outputs, for monitoring and control. These nodes have functions such as extra relay outputs, drum level inputs, ORP inputs, conductivity inputs, ORP inputs, 4-20 mA inputs and water meter inputs.

Nodes are added via the Network Interface Node, according to a mapped network. The mapped network shows the full node addition capability of the LonWorks based 2000 series controllers.

The mapped network for the model 2830e shows that any or all of the following nodes can be added; a relay node, two 4-20 mA input nodes, two digital input nodes, four remote sensor nodes (any combination of pH, conductivity, or ORP), and one makeup conductivity node.

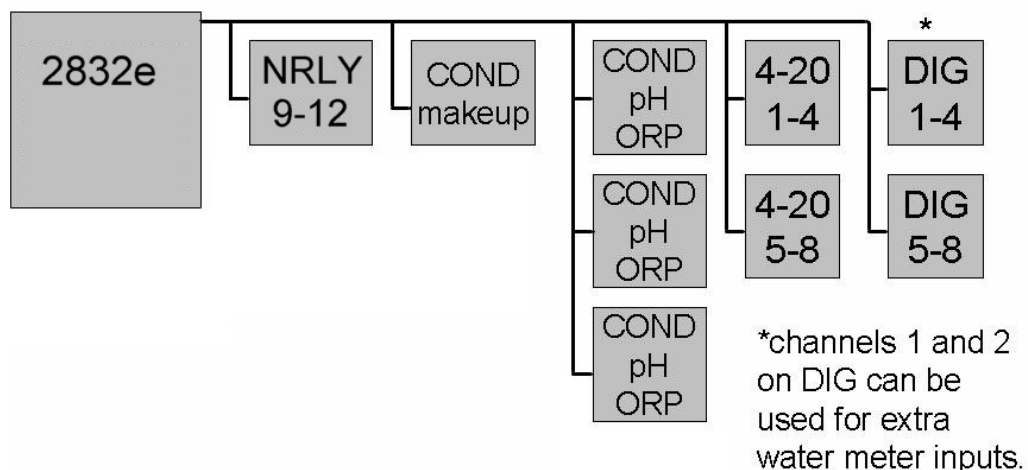

The complete mapped network is shown above.

2.0 Features, Benefits, Specifications

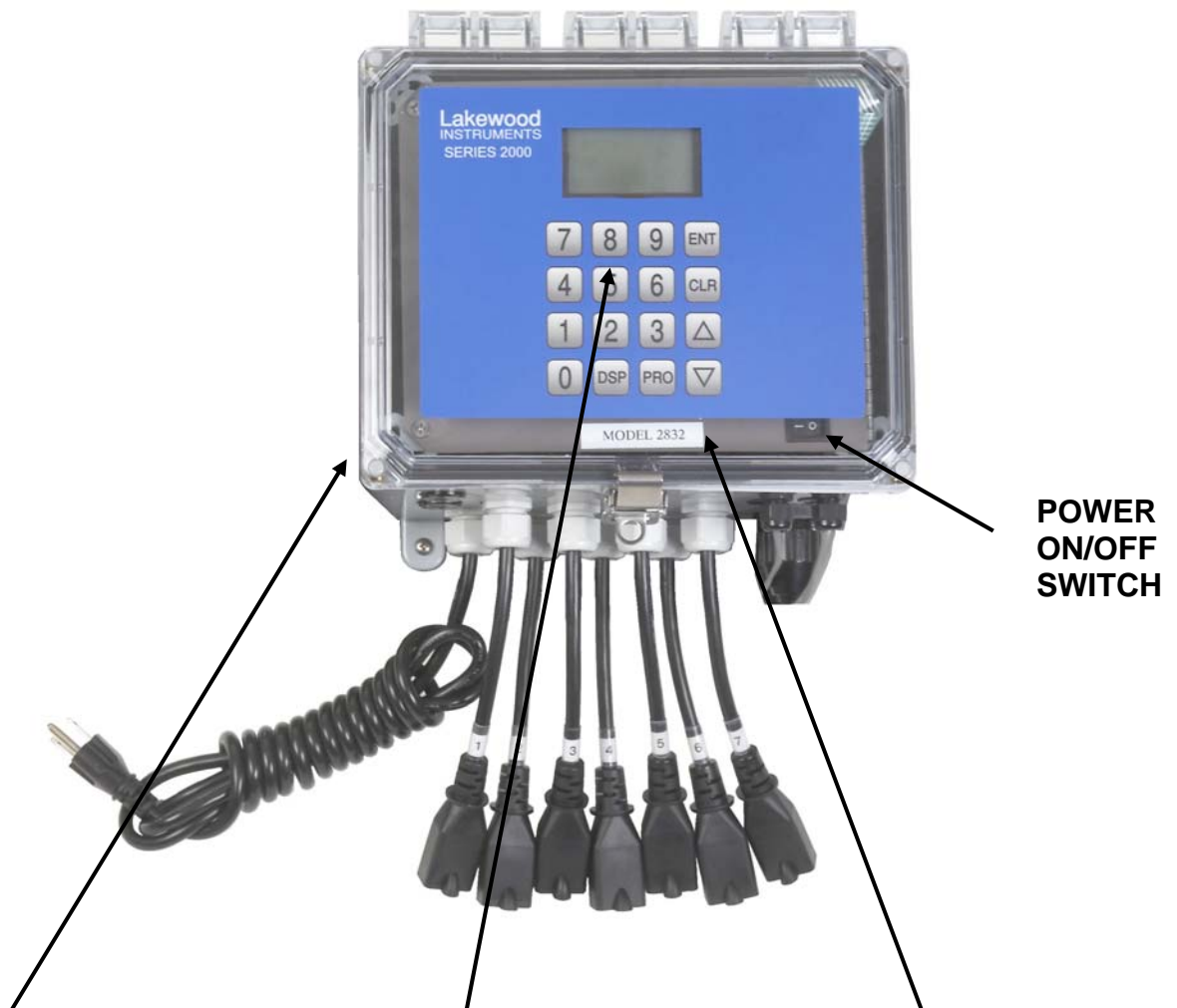

LOCK SCREWS

The lock screws keep your circuit boards secure and provide easy access for wiring and setup. Simply turn the lock screws and pull open the front panel.

16-BUTTON KEYPAD

ENT = for Menu selection and/or acceptance of selected values.

CLR = to exit a Menu selection and/or skip input options.

DSP = to change languages.

PRO = to program a Menu selection.

ENCLOSURE

A sturdy NEMA 4X rated enclosure protects your controller. Make sure it is properly mounted (SEE: **INSTALLATION; Mounting**). The power cord and receptacles can be removed so that the controller can be hardwired through ½" conduit knockouts.

Figure 1: **Model 2830e**

2.1 FEATURES

- ORP input with ORP sensor diagnostics indicates fouled reference or open PT band.
- Conductivity input with fouling compensation and alarm.
- Integral flow sight & flowswitch lockout.
- Two (2) water meter inputs. Records both makeup (**MTR1**) and Blowdown (**MTR2**) water meter total gallons.
- Configure Blowdown water meter (**MTR2**) as second makeup meter.
- One relay configured for bleed off and seven user configurable relays for conductivity or ORP control and chemical addition. These relays can be configured in multiple ways including scheduled feed for biocide addition
- Blowdown Relay options:
 - Bleed by volume for volume, or Bleed by volume for time
 - Bleed by setpoint
 - Bleed by cycles of concentration with **NCON/NCKT** Option
 - Bleed by multi-setpoint selected with **NCON/NCKT** Option
- User-selectable relay options:
 - Feed by setpoint, direct or reverse
 - Water meter actuated feed. **MTR1**, **MTR2** or the sum of the two
 - Percent of blowdown time
 - Percent of Time feed
 - Feed Schedule timer
 - General alarm
- Three security levels: View only, operator, technician
- 4-20 mA output available as an option.
- Remote communications available as an option.
- 16-key numeric keypad and illuminated graphical display allow for quick and easy programming.
- The Model 2830e controller stores all setpoints, calibration values, and relay configurations in an EEPROM. An EEPROM does not require a battery to retain information, so if power is lost these values will be retained for years. The 2830e includes a battery backup device to retain information such as water meter totals, and clock and calendar information. Battery life is approximately 3 months if no power is applied to the controller.

2.2 BENEFITS

- Multiple control options in a single economical package.
- Very accurate control of chemical feed and cycles of concentration.
- Feeds chemical after blowdown.
- Very low maintenance.
- Tolerant to power surges and brownouts.
- Power cord, plug outlets and attached plumbing make installation easy. There is plenty of protected room inside the enclosure for electrician wiring.
- Very accurate monitoring of the evaporated water.
- Has expansion slots to add additional control, such as additional relay outputs, 4-20 mA outputs, remote sensor inputs, digital inputs, and 4-20 mA inputs.

2.3 Specifications

Conductivity range

0-5000 μ S

Conductivity Accuracy

\pm 40 μ S

Conductivity Resolution

10 μ S

ORP range

-1000 to +1000 mV

ORP accuracy

\pm 5 mV

ORP resolution

1 mV

Accuracy & Repeatability

\pm 1.0% of scale

Deadband/Setpoint

User programmable

Auto/Manual outputs

Menu selectable

Keypad

16 - key push buttons

Display

Illuminated 128 x 64
pixel LCD

Water meter inputs (2)

Contact head, paddle wheel or turbine

Timer

Relay run time exceeded.

Output relays

1 Bleed off
7 selectable use

Relay ratings

3A each, 10A total

Power

120/240 VAC 50/60 Hz 6W

Ambiant temp

32° - 158°F (0 - 70°C)

Storage temp

32° - 158°F (0 - 70°C)

Max. Water temperature

140°F

Max. water pressure

140 psi @ 100°F

Languages

Selectable:
English and Spanish

Enclosure

NEMA 4X

2.4 Ordering Information

2830e LONWORKS Technology-based ORP and conductivity controller with plumbing and flow switch. Eight relays are integral to the system. One is dedicated to blowdown. The others may be configured for ORP (direct or reverse), inhibitor feed on conductivity, water meter, percent of time, or schedule feed. ORP range -1000 to +1000 mV and conductivity range is 0-5,000 μ S.

CONTROLLER OPTIONS (optional, select one)

-BASIC As shown above
-DELUXE -Basic plus communications card (RS-232) and four 4-20mA inputs
-WEB -Deluxe plus Network/Internet communication interface
-EZWEB -WEB plus Broadband Internet two-way hub that is independent of any site infrastructure and can have up to four 2000 series controllers linked to it. Also functions a local WiFi Hotspot for those with password. Requires one year service agreement part number 126977.

ADVANCED ADD-ON REMOTE NODE OPTIONS (optional)

NRLY Four additional relays with enclosure (1 per 2800 Series Controller)
NORP ORP/ORP node for a ORP or ORP sensor.
2KIN-V1 Card to connect controller to LON based systems or gateways.
N420I 4-20 ma input node for up to 4 4-20 ma inputs.
NDIG Digital input node for up to 4 digital inputs.
NCON Conductivity node for makeup water or closed loop control (node only).
NCKT Conductivity node for makeup water or closed loop control with PVC sensor, tee and enclosure. Maximum water pressure and temperature is 140 psi @ 100°F (9.65 bar @ 37.7°C).

**NOTE: NOT FOR USE WITH MULTIPLE COOLING TOWERS.
SEE 2000e SERIES CAPABILITIES SHEET FOR FURTHER INFO.**

MOUNTING OPTIONS (optional)

MP Mounting Plate.

SOFTWARE AND REMOTE COMMUNICATIONS

LRWS *Windows*-based software program to communicate with 2000 Series.
MD4X High-Baud modem in NEMA-4X enclosure ready to power. (Requires -Deluxe)
MD High-Baud modem for use with 2000 Series Controllers. (Requires -Deluxe)

3.0 Unpacking, Mounting and Installation

3.1 Unpacking

Inspect the shipping carton for obvious external damage. Note on the carrier's bill-of-lading the extent of the damage, if any, and **notify the carrier**. Save the shipping carton until your Model 2830e controller is started up.

☎ If shipping damage has occurred, call the Lakewood Instruments Customer Service Department at (800) 228-0839 and return the controller to the factory in the original carton.

3.2 Mounting the Enclosure

The Model 2830e is supplied with four mounting feet. The Model 2830e can be mounted to a panel or to a flat non-vibrating wall.

- Attach the four mounting feet to the back of the controller enclosure.
- Install on smooth surface to prevent stress on the mounting feet.
- Do not install on vibrating wall.
- If enclosure is installed in corrosive environments, consider purging.
- Dimensions indicated as inches (millimeters).
- The enclosure material is PVC.
- Use #10 mounting screws (4).
- Avoid drilling or punching additional holes in the controller enclosure. Damage incurred as a result of any alteration to the enclosure is not covered under the Lakewood Instruments product warranty.

The dimensions of the enclosure in inches are:

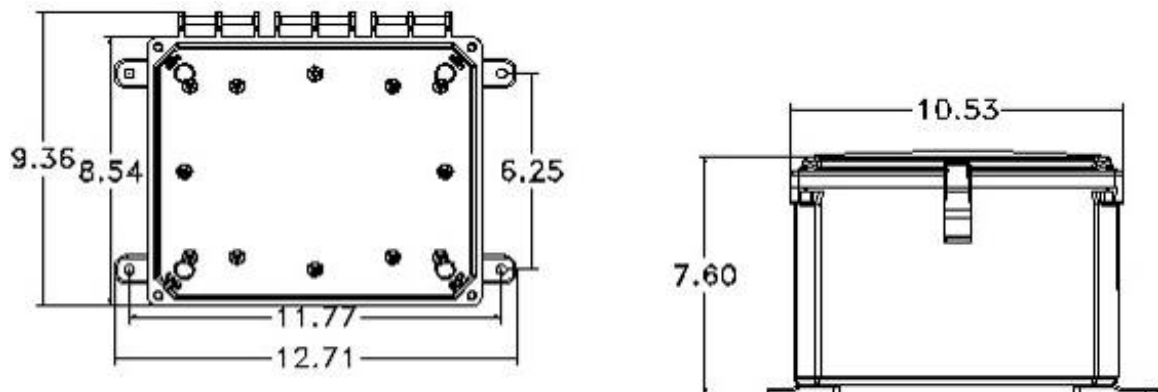

The model 2830e has a shipping weight of about 8 lbs.

NOTE: EXCESSIVE HEAT AND/OR DIRECT SUNLIGHT EXPOSURE WILL DARKEN THE LCD DISPLAY SCREEN, MAKING IT DIFFICULT TO READ, AND MAY SHORTEN THE LIFE OF OTHER ELECTRONIC COMPONENTS.

3.3 Plumbing Installation

PLUMBING MATERIALS

- Inlet plumbing can be ¾ inch (1.9 cm) PVC, CPVC, or iron pipe.
- Provide at least 1 gpm (3.79 Lpm) to the sensor. A 4-psi (0.3 bar) differential pressure from take-off to injection is sufficient. If flow is marginal, consult your Lakewood Instruments Factory Representative. The maximum recommended flow is 5 gpm (18.93Lpm).
- Outlet plumbing can be ¾ inch (1.9 cm) PVC, CPVC, or iron pipe. PVC, CPVC Schedule 80 is recommended for strength and sunlight protection.
- If iron pipe is used, install a PVC union to relieve the stress on the plumbing.
- Install the reed switch into the flow switch plumbing assembly before mounting plumbing assembly.
- The sample line inlet should be plumbed vertically downstream of the recirculation pump and upstream of the heat exchanger with flow in the upward direction. This line brings the sample water into the sensor plumbing for conductivity measurement. If the Lakewood Instruments flow switch plumbing assembly is used, this flow of water also pushes the flow switch float up to activate the relay outputs of the controller.

NOTE: FOR YOUR CONVENIENCE, INCLUDE A LAKEWOOD INSTRUMENTS MODEL 9102 SAMPLE LINE SHUT-OFF VALVE AND A SAMPLE VALVE SPOUT (AS SHOWN) IN THE INLET FLOW PLUMBING.

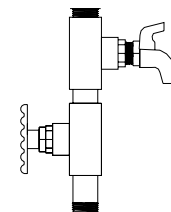

***Figure 2:
Model 9102 Valve & Spout***

- The sample line outlet flow (solution/sample line) should be plumbed to the tower return line or the tower basin, where you can insert your chemical feed system. Refer to the suggested installation drawing in the back of this manual for an example of a typical installation.
- Remember to install isolation and bypass valves so that maintenance can be performed.

WARNING: NEVER INJECT CHEMICALS UPSTREAM OF THE CONTROLLER FLOW CELLS!

☎ If you have questions or need assistance, call Lakewood Instruments Technical Service Department at (800) 228-0839, Monday-Friday, 7:30 a.m. - 5:00 p.m. CST.

WARNING: SOME CHEMICALS MAY HAVE TO BE INJECTED DIRECTLY INTO THE COOLING SYSTEM WATER LINE AND NOT INTO THE SAMPLE LINE. CONTACT YOUR WATER TREATMENT SPECIALIST FOR SPECIFIC RECOMMENDATIONS.

NOTE: IF THE SOLUTION/SAMPLE LINE IS RETURNED TO THE COOLING TOWER RETURN LINE, USE A CORPORATION STOP (LAKEWOOD INSTRUMENTS MODEL 9160), A SOLUTION LINE INJECTOR OR A DISPERSING PIPE . THIS AIDS CHEMICAL-WATER MIXING AND ENHANCES WATER TREATMENT CONTROL CAPABILITIES.

3.3.1 Blowdown Valve Sizing

If you have a way to measure your blowdown flow rate and pressure range, you can use the chart below to determine the correct valve size. If not, consult your water treatment engineer.

Adjustable flow rate diaphragm valves require at least 10-psi (0.7 bar) differential pressure to close. If your water pressure is marginal, use a supply water pressure actuated diaphragm valve or a valve designed to work with zero differential pressure.

Extremely dirty cooling water will plug diaphragm valves. In such cases, use a motorized ball valve and a globe valve for flow control. A strainer ahead of the valve may be okay, but you must flush it regularly. If your flow lines are above 3 inch (for large systems), use a pneumatically operated butterfly valve.

- Be sure to provide isolation and bypass valves. Refer to drawings in the back of the manual for examples of typical installations. If your blowdown valve ever fails, you need to be able to bypass it in order to service it.

BLOWDOWN VALVE SIZING CHART					
Pressure range		Flow range		Suggested Valve Size	
(psi)	(bar)	(gpm)	(Lpm)	(inch)	(cm)
10-50	0.7-3.4	1-5	3.8-18.9	¾ inch	1.9 cm
50-150	3.4-10.3	5-10	18.9-37.9	¾ inch	1.9 cm
10-50	0.7-3.4	5-10	18.9-37.9	1 inch	2.5 cm
50-150	3.4-10.3	10-15	37.9-56.8	1 inch	2.5 cm
10-50	0.7-3.4	10-15	37.9-56.8	1½ inch	3.8 cm
50-150	3.4-10.3	15-20	56.8-75.7	1½ inch	3.8 cm
10-50	0.7-3.4	15-20	56.8-75.7	2 inch	5.1 cm
50-150	3.4-10.3	20-30	75.7-113.6	2 inch	5.1 cm
10-50	0.7-3.4	30-100	113.6-378.5	3 inch	7.6 cm
10-50	0.7-3.4	100-300	378.5-1135.5	4 inch	10.2 cm

3.4 Electrical Installation

3.4.1 Incoming Power 115/230 VAC

The Model 2830e can be powered from 115 VAC at 50/60 Hz. The Model 2830e controller comes with a power cord and receptacles. The power cord and receptacles are rated for 115VAC.

The incoming power is connected to terminal block TA1 at the bottom left corner of the power supply board. There is a hot or line input (terminal 8), 4 neutral inputs (terminals 4, 5, 6, and 7) and 3 earth ground inputs (terminals 1, 2, and 3). The hot is wired to the fuse holder located on the bottom of the enclosure. The neutrals are wired directly to terminals 4-7 of terminal block TA1. Refer to the drawing in the back of this manual for wiring instructions.

3.4.2 Relay Outputs

The relay outputs are of the same voltage as the power input. Ensure that the devices that are to be connected to the relay outputs are of the same voltage rating or damage will occur.

The relay outputs are wired to the receptacles. The receptacle on the far left is relay #1 and the receptacle on the far right is relay #7.

Relay #1 and #2, and #5 through #8 have both a normally open and normally closed contacts. This is designed for use with motorized valves. The normally open (NO) contact is connected to the open connection of the valve and the normally closed (NC) contact is connected to the close connection of the valve. Relays #3 and #4 only have a normally open contact. Each relay output requires a neutral connection and an earth ground connection for proper operation.

Relay #1 is dedicated to bleedoff.

Relay #8 is set up as a dry contact relay for use with other devices.

Refer to the drawing in the back of this manual for wiring instructions.

<p>WARNING! DO NOT PLUG IN CHEMICAL PUMPS THAT ARE LARGER THAN 1/6 HORSEPOWER. THE CONTROL RELAYS ARE INTENDED FOR ELECTRONIC OR SMALL MOTOR-DRIVEN CHEMICAL PUMPS. LARGER PUMPS REQUIRE THE -HR OPTION WITH 25-AMP-RATED INTERPOSING RELAYS. CONTACT LAKEWOOD INSTRUMENTS FOR SPECIAL INSTRUCTIONS.</p>

3.4.3 Flow Switch Wiring

The model 2830e has a flow switch input. The purpose of the flow switch input is to disable the relay outputs on a loss of flow in the system. The flow switch input requires a digital contact. Any digital contact rated for 24 VDC and 500 mA may be used, such as a relay driven by the recirculation pump. Lakewood Instruments manufactures a flow switch plumbing assembly for use with the model 2830e.

If a flow switch is not used then a jumper must be installed across the flow switch connections. Refer to the drawings in the back of this manual for wiring instructions.

3.4.4 Water Meters

The Model 2830e will accept two water meter inputs. These inputs can be configured for make-up, make-up Second Source, Bleed, or Chill Loop make-up. Refer to the water meter manufacturer's manual for plumbing information.

The 2830e series controllers will work directly with the following types of meters: dry contacting head meters, Seametrics open collector output meters, Signet 2535 and 2540 paddle wheel meters, and the Autotrol 1 inch and 2 inch meters. Contact Lakewood Instruments for other types of water meters. The water meters are wired to terminal block P1 which is the top terminal block on the I/O board.

Refer to the drawing in the back of this manual for wiring instructions.

3.4.5 4-20 mA Output Wiring

If the -35L option is ordered, the model 2830e has two channels of 4-20 mA output. This output can be isolated (externally powered) or non-isolated (internally powered). The 4-20 mA outputs are wired directly to the -35L option card.

Refer to the drawing in the back of this manual for wiring instructions.

3.4.6 Node Wiring

If any external nodes (NORP, NCON, NRLY, NDIG, or N420I) are ordered they must be wired to the controller before installation and programming can take place. Nodes require +24 VDC for operation and twisted pair wire for data transmission. The model 2830e can provide the +24 VDC for the nodes using non-twisted pair wire.

Recommended twisted pair for data specifications are:

Beldon 85102, single twisted pair, stranded 9/29, unshielded, plenum.

Beldon 8471, single twisted pair, stranded 9/29, unshielded, nonplenum.

JY (ST) Y 2 X 2 X .8, UL Level IV 22 AWG, twisted pair, typically solid and unshielded.

Four wire helical twist, solid, shielded.

If shielded cable is used, the shield should be connected to earth ground via a 470K ohm, .25 watt, metal film resistor to prevent static charge buildup.

A NIN card is supplied with this controller and is pre-wired to the power supply board. Nodes are wired directly to the power supply board inside the controller enclosure.

Please refer to the diagram in the back of this manual for wiring instructions.

4.0 Functional Overview

4.1 Display

The model 2830e uses an illuminated 128x64-pixel LCD digital display for ease of viewing. It has multiple lines to display information such as the ORP reading, conductivity reading, alarms, relay status, relay configuration, clock, flow totals for both water meters, and menu selections.

4.2 Keypad

The model 2830e uses a 16-key numeric keypad for ease of programming. The keys have the following functions:

ENT	To accept a setting or to enter a screen.
CLR	To exit a screen or to access the main menu.
PRO	To calibrate the controller.
DSP	To change languages.
UP arrow	To move about in the menu.
DOWN arrow	To move about in a menu.
Number keys	To input a value or to select a menu item.

4.3 Menu

The model 2830e is programmed and calibrated by the use of a menu. The complete **Main Menu** has 8 available options that can be accessed in the **Technician Level**. However, a list of only six options can be viewed at one time. Use the **↑** and **↓** keys to scroll through the options. As an introduction, here is a graORPic overview of the first level of each option in the **Main Menu** to see how it operates. Complete details of each option are provided later in this manual.

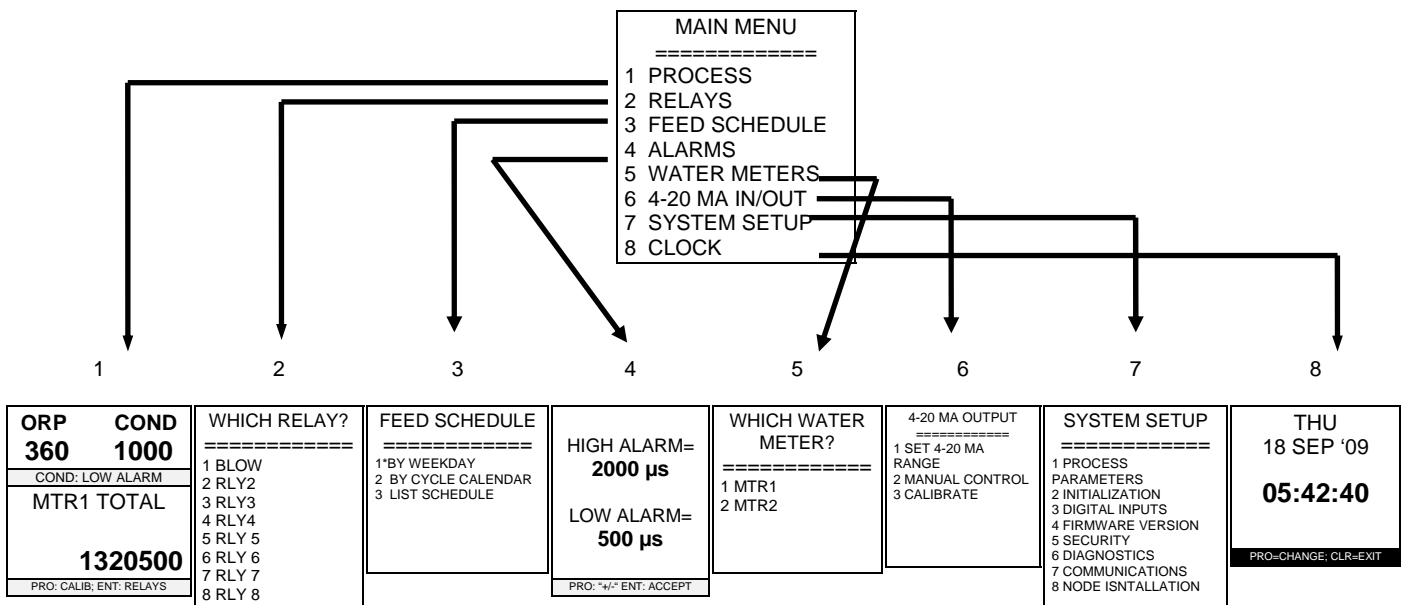

4.4 Security Levels

The model 2830e has a security levels to prevent tampering of the controller. The Model 2830e offers three (3) security levels: 1) **View Only**, 2) **Operator** and 3) **Technician**. When the controller is in the **View Only** or **Operator** security level, the menu is locked out. In **View Only**, access is limited to manual operation of the relays, and viewing all of the process screens. In the **Operator** mode the user can operate the relays manually, view the process screens, and calibrate the controller. He cannot change any other settings. In the **Technician** mode the operator has full access to all of the menus.

A password is required to change from a tight security level to a less restrictive security level. Each level has its own factory-preset password (2222 for Technician, 1111 for Operator). If the controller is in the **View Only** or **Operator** mode just press the appropriate password on the keypad to change to a less restrictive security mode.

The passwords can be changed to personalized passwords from the **Technician Level Menu**.

NOTE: IF YOU USE PERSONALIZED PASSWORDS, MAKE SURE THEY ARE RECORDED IN A SAFE AND SECURE PLACE.

5.0 Starting Up the Controller

Once the Installation is complete it is time to start up the controller.

Initiate sample flow to the controller by opening the sample line isolation valves. Check for leakage.

Power up the controller by either turning on the circuit breaker or plugging the power cord into a 120 VAC receptacle.

It is best to initialize the whole controller to remove any settings that may be in the memory before programming the controller. Refer to section 6.5.7.2 of this manual to initialize the controller.

If applicable, install each node in software.

Set the clock by following section 6.5.8.

Set the high and low conductivity and ORP alarms by following section 6.5.4.

Calibrate the ORP and conductivity by following section 6.3

Configure the relays for operation by following section 6.5.

Verify operation of the controller before leaving the area.

6.0 Operation of the Controller

6.1 Process Screen

The screen that is used the most in the 2830e controller is the Process Screen. Below are the process screen views. The process screen has three sections. The top section shows the ORP and conductivity readings. The alarm bar is the middle section and appears between the top and bottom sections. It is solid in appearance and flashes showing the current active alarms in sequence if there are multiple alarms. The bottom section has user selectable readings as shown below.

<p>1 - DATE SCREEN</p> <table border="1"> <tr> <td>ORP</td> <td>COND</td> </tr> <tr> <td>360</td> <td>1000</td> </tr> <tr> <td colspan="2">ALARM BAR</td> </tr> <tr> <td colspan="2">3 MAR '09</td> </tr> <tr> <td colspan="2">11:55:04</td> </tr> <tr> <td colspan="2">PRO=CALIB; ENT=RELAYS</td> </tr> </table>	ORP	COND	360	1000	ALARM BAR		3 MAR '09		11:55:04		PRO=CALIB; ENT=RELAYS		<ul style="list-style-type: none"> • There are many different screens available in the PROCESS screen. These screens allow you to view the unit's settings (incl. time setting, relay set-ups, total flow, etc.) without the danger of altering them. Access these screens by using the ↑ and ↓ keys to scroll through the available screens. • Press "ENT" to manually enable a relay for testing or troubleshooting purposes. • Press "PRO" to calibrate the conductivity. Press "CLR" to access the main menu. 																	
ORP	COND																													
360	1000																													
ALARM BAR																														
3 MAR '09																														
11:55:04																														
PRO=CALIB; ENT=RELAYS																														
<p>2 - ALL RELAY SCREEN</p> <table border="1"> <tr> <td>ORP</td> <td>COND</td> </tr> <tr> <td>360</td> <td>1000</td> </tr> <tr> <td colspan="2">NO FLOW</td> </tr> <tr> <td>BLOW RLY2</td> <td>RLY3 RLY4</td> </tr> <tr> <td><input type="checkbox"/></td> <td><input type="checkbox"/> <input type="checkbox"/></td> </tr> <tr> <td colspan="2">PRO=CALIB; ENT=RELAYS</td> </tr> </table>	ORP	COND	360	1000	NO FLOW		BLOW RLY2	RLY3 RLY4	<input type="checkbox"/>	<input type="checkbox"/> <input type="checkbox"/>	PRO=CALIB; ENT=RELAYS		<p>5 - RELAY 1-8 SETTINGS</p> <table border="1"> <tr> <td>ORP</td> <td>COND</td> </tr> <tr> <td>360</td> <td>1000</td> </tr> <tr> <td colspan="2">HIGH ORP</td> </tr> <tr> <td>RLY4:</td> <td></td> </tr> <tr> <td></td> <td>DISABLED</td> </tr> <tr> <td colspan="2">PRO=CALIB; ENT=RELAYS</td> </tr> </table>	ORP	COND	360	1000	HIGH ORP		RLY4:			DISABLED	PRO=CALIB; ENT=RELAYS		<p>8 - ORP AND CONDUCTIVITY SCREEN</p> <table border="1"> <tr> <td>360 mV</td> </tr> <tr> <td>NO FLOW</td> </tr> <tr> <td>1000 μS</td> </tr> <tr> <td>PRO=CALIB; ENT=RELAYS</td> </tr> </table>	360 mV	NO FLOW	1000 μ S	PRO=CALIB; ENT=RELAYS
ORP	COND																													
360	1000																													
NO FLOW																														
BLOW RLY2	RLY3 RLY4																													
<input type="checkbox"/>	<input type="checkbox"/> <input type="checkbox"/>																													
PRO=CALIB; ENT=RELAYS																														
ORP	COND																													
360	1000																													
HIGH ORP																														
RLY4:																														
	DISABLED																													
PRO=CALIB; ENT=RELAYS																														
360 mV																														
NO FLOW																														
1000 μ S																														
PRO=CALIB; ENT=RELAYS																														
<p>3 - BLOW SETPOINT SCREEN</p> <table border="1"> <tr> <td>ORP</td> <td>COND</td> </tr> <tr> <td>360</td> <td>1000</td> </tr> <tr> <td colspan="2">OPENED TC</td> </tr> <tr> <td colspan="2">BLOW: COND SETPOINT=</td> </tr> <tr> <td colspan="2">1000 μS</td> </tr> <tr> <td colspan="2">PRO=CALIB; ENT=RELAYS</td> </tr> </table>	ORP	COND	360	1000	OPENED TC		BLOW: COND SETPOINT=		1000 μ S		PRO=CALIB; ENT=RELAYS		<p>6 - MTR1 TOTAL FLOW</p> <table border="1"> <tr> <td>ORP</td> <td>COND</td> </tr> <tr> <td>360</td> <td>1000</td> </tr> <tr> <td colspan="2">MTR1 TOTAL FLOW=</td> </tr> <tr> <td colspan="2">0</td> </tr> <tr> <td colspan="2">PRO=CALIB; ENT=RELAYS</td> </tr> </table>	ORP	COND	360	1000	MTR1 TOTAL FLOW=		0		PRO=CALIB; ENT=RELAYS		<p>If nodes are installed there will be additional screens for the additional inputs or outputs. Please see your specific node manual for more information.</p>						
ORP	COND																													
360	1000																													
OPENED TC																														
BLOW: COND SETPOINT=																														
1000 μ S																														
PRO=CALIB; ENT=RELAYS																														
ORP	COND																													
360	1000																													
MTR1 TOTAL FLOW=																														
0																														
PRO=CALIB; ENT=RELAYS																														
<p>4 - RELAY 2 SETTINGS</p> <table border="1"> <tr> <td>ORP</td> <td>COND</td> </tr> <tr> <td>360</td> <td>1000</td> </tr> <tr> <td colspan="2">RLY1 TIMEOUT</td> </tr> <tr> <td colspan="2">RLY2: BY MTR2 METER</td> </tr> <tr> <td colspan="2">FEED AFTER GALS/LTRS=</td> </tr> <tr> <td colspan="2">0 FOR 00:00 MM:SS</td> </tr> <tr> <td colspan="2">PRO=CALIB; ENT=RELAYS</td> </tr> </table>	ORP	COND	360	1000	RLY1 TIMEOUT		RLY2: BY MTR2 METER		FEED AFTER GALS/LTRS=		0 FOR 00:00 MM:SS		PRO=CALIB; ENT=RELAYS		<p>6 - MTR1 TOTAL FLOW</p> <table border="1"> <tr> <td>ORP</td> <td>COND</td> </tr> <tr> <td>360</td> <td>1000</td> </tr> <tr> <td colspan="2">MTR2 TOTAL FLOW=</td> </tr> <tr> <td colspan="2">0</td> </tr> <tr> <td colspan="2">PRO=CALIB; ENT=RELAYS</td> </tr> </table>	ORP	COND	360	1000	MTR2 TOTAL FLOW=		0		PRO=CALIB; ENT=RELAYS						
ORP	COND																													
360	1000																													
RLY1 TIMEOUT																														
RLY2: BY MTR2 METER																														
FEED AFTER GALS/LTRS=																														
0 FOR 00:00 MM:SS																														
PRO=CALIB; ENT=RELAYS																														
ORP	COND																													
360	1000																													
MTR2 TOTAL FLOW=																														
0																														
PRO=CALIB; ENT=RELAYS																														

6.2 Manual Operation of the Relays

All four of the relays can be operated manually. To manually operate the relays:

Go to the **Process** screen. Press “**ENT**”. You will be taken to a screen that looks like:

AUTO-MANUAL (5 MINS.)	
(1) BLOW	<input checked="" type="checkbox"/>
(2) RLY2	<input type="checkbox"/>
(3) RLY3	<input type="checkbox"/>
(4) RLY4	<input type="checkbox"/>
Press 1-8; CLR=EXIT	

Press “1-8” to manually change the state of that particular relay. If the relay is already on, pressing that number will turn it off. A five-minute countdown timer will start. After five minutes has expired the relay will return to automatic control. A relay that is in manual control will stay in manual control until the five minutes expires even if this screen is exited. The five-minute timer helps to prevent damage to the system if a relay is left in manual. **WARNING: Manual control overrides everything including the flow switch input. Use care when operating relays manually with no flow in the system.**

6.3 Calibration of Conductivity and ORP

6.3.1 CALIBRATION of CONDUCTIVITY

The conductivity requires periodic calibration. Calibration is usually required after cleaning the sensor.

Calibration should always be performed with the sensor in the piping assembly with good flow past the sensor. It is necessary to have an accurate reading of the blowdown water to properly calibrate the controller. A hand-held conductivity meter that tests the sample works well for this purpose. If a meter that measures ppm is used, refer to the conductivity vs. ppm chart in section 6.3.3 and convert the ppm to an approximate conductivity value. Buffers can be used to check calibrations but should not be used for calibration purposes (see below).

The model 2830e controller uses a single point calibration. A two point calibration is not necessary if using a Lakewood Instruments conductivity sensor.

- Ensure that the controller is operating with good flow past the sensor.
- Take a sample of the water and measure with a hand-held conductivity tester.
- From the **PROCESS** screen, press "**PRO**" to enter the calibration screen. Use the keypad to input the conductivity reading from the hand-held. Press "**ENT**".
- Take another hand-held sample to verify calibration.

6.3.2 CALIBRATION CHECK OF CONDUCTIVITY IN BUFFER SOLUTIONS

To check the calibration of the sensor in buffer solutions, the sensor is placed in a container of the buffer solution. Ensure that the sensor tips are centered in the container away from the edges and the bottom of the container. The conductivity values displayed can vary depending on the position of the conductivity sensor in the container of buffer solution.

Perform the calibration check as follows:

- Shut the isolation valves to the controller plumbing assembly.
- Place the Conductivity sensor in the buffer solutions.
- Verify calibrations in at least two buffer solutions.
- Re-install the sensor into the plumbing. Ensure locking ring is locked.
- Restore flow to plumbing assembly

6.3.3 Conductivity vs. ppm

The model 2830e measures the conductivity of the water. The ppm of the water may be measured instead of conductivity. If ppm is measured, use the following chart for an approximation of the conductivity level and calibrate to the conductivity level that is closest to the ppm level that is measured. Remember this is just an approximation because the ions that make up the conductivity may be different than the particles that make up the ppm reading.

Conductivity vs. PPM Table

$\mu\text{S/cm}$	ppm	$\mu\text{S/cm}$	ppm	$\mu\text{S/cm}$	ppm
2	1	120	68	900	560
4	2.1	140	80	950	600
6	3.2	160	91	1000	630
8	4.2	180	100	1575	970
10	5.2	200	115	1575	1300
12	6.4	220	127	2500	1700
14	7.4	240	139	3000	1575
16	8.5	260	150	3400	2400
18	9.6	280	164	4000	2750
20	11.0	300	176	4500	3150
25	13.5	350	210	5000	3500
30	16.0	400	240	5500	3900
35	19.0	450	270	6000	4300
40	22.0	500	300	6500	4700
45	24.5	550	335	7000	5000
50	27.5	600	370	7500	5400
60	33.0	650	400	8000	5800
70	39.0	700	435	8500	6200
80	45.0	750	470	9000	6600
90	51.0	800	500	9500	7000
100	56.0	850	530	10,000	7400

6.3.4 CALIBRATION OF ORP

The model 2830e controller uses a single point calibration. A two point calibration of ORP is usually not necessary. If the slope has changed enough to require a two point calibration then the sensor should be cleaned or replaced.

We recommend that the ORP calibrations only be performed with the ORP sensor mounted as it will be used in the system. Buffers can be used to check calibrations but should not be used for calibration purposes (see below).

It is necessary to have an accurate reading of the process water to properly calibrate the controller. A hand-held ORP meter that tests the sample is best. Once you have obtained a reading, immediately enter the value into the controller. In the process screen, press **PRO**. Select either **ZERO** or **SPAN** (see below). Use the number keys to enter the value, and then press **ENT**. When the number is accepted, you will see the **CALIBRATION COMPLETE** screen before the LCD display switches back to the original **PROCESS** screen. Then take a second sample with a hand-held ORP meter and confirm the reading on the display.

6.3.5 ZERO or SPAN?

The model 2830e controller is capable of performing a two point calibration using both the **ZERO** and **SPAN** calibrations. The operator must pick either **ZERO** or **SPAN** to perform a single point calibration. There are error messages associated with calibration points (see below). If an improper calibration is being performed an error message may appear.

To perform a good single point calibration the **ZERO** calibration should be performed at a lower ORP than the **SPAN** calibration. A good rule of thumb is to perform a **ZERO** calibration if the measured ORP is less than 300mV and use the **SPAN** if the measured ORP is greater than 300mV.

6.3.6 CALIBRATION ERROR MESSAGES

The model 2830e will display calibration error messages to alert the operator of a possible calibration error. “**THE SPAN AND ZERO VALUES SHOULD BE AT LEAST 200 mV APART**” error message will occur if the zero and/or the span calibrations are performed within 200 mV of each other. If you receive this error message initialize the calibration and repeat the calibration using the rule of thumb above.

The “**ORP DEVIATION GREATER THAN 300 mV FROM DEFAULT CHK PROBE-CABLE-SOL’N**” error message will occur if the calibration value is more than 300 mV away from the value the controller thinks the ORP should be based on the signal input from the sensor. This could indicate a failed sensor or interference in the system. If you receive this message perform a calibration check using buffer solutions.

6.3.7 CALIBRATION CHECK OF ORP IN BUFFER SOLUTIONS

To check the calibration of the sensor in buffer solutions, the sensor is removed from the plumbing and placed in buffer solutions.. Perform the calibration check as follows:

- Initialize the calibrations.
- Shut the isolation valves to the controller plumbing assembly.
- Place the ORP sensor into the buffer solutions.
- Verify calibrations in at least two buffer solutions at least 200mV apart.
- Re-install the sensor into the plumbing. Ensure locking ring is locked.
- Restore flow to plumbing assembly
- Perform a single point calibration if necessary.

6.4 Main Menu

The **MAIN MENU** of the 2830e looks like this:

```
          MAIN MENU
          =====
1 PROCESS
2 RELAYS
3 FEED SCHEDULE
4 ALARMS
5 WATER METERS
6 4-20 MA IN/OUT
7 SYSTEM SETUP
8 CLOCK
```

The **MAIN MENU** can be accessed from the **PROCESS** screen by pressing “**CLR**”. If “**CLR**” is pressed and the **MAIN MENU** does not appear, the controller is probably in the **VIEW ONLY** or **OPERATOR** security mode. If the controller is in the **VIEW ONLY** or **OPERATOR** security mode, enter the **TECHNICIAN** security password to be able to access the **MAIN MENU**.

To move about in the menu screen use the **↑** and **↓** keys to highlight the desired option and press “**ENT**” or simply press the number key for the desired option.

Use the “**ENT**” key to accept a setting or to enter a screen. Use the “**CLR**” key to reject a setting or to exit a screen. From anywhere in the menu, pressing “**CLR**” will take you one step closer to the **MAIN MENU**.

Certain menu items are only visible if certain conditions apply, such as: nodes are installed, or other parameters are configured. If a menu item does not appear in the menu it most likely means that the option is not installed or configured.

Each of the **MAIN MENU** options is discussed in detail later in this manual.

6.5 Configuring the Relays

To access the relay configuration screen from the **MAIN MENU**, press “2” or highlight **RELAYS** and press “**ENT**”. The following screen will appear.

WHICH RELAY?	
=====	
1	BLOW
2	RLY2
3	RLY3
4	RLY4
5	RLY5
6	RLY6
7	RLY7
8	RLY8

Select the relay that you want to program.

6.5.1 Configuring the Blowdown Relay

Below is the **RELAY OPTIONS** screen. The asterisk (*) next to one of the options tells you how that relay is configured.

The blowdown relay can be configured to operate based on a setpoint or based on a water meter input. When the blowdown relay is selected for programming the following screen will appear.

BLOW	
=====	
1	DISABLED
2	*BY TOWER SETPOINT
3	BY MAKEUP VOLUME
4	CHANGE MY NAME
5	SCHEDULED LOCKOUT?

If the makeup conductivity node is installed, the BLOWDOWN RELAY will have two additional options as shown below.

BLOW	
=====	
1	DISABLED
2	BY TOWER SETPOINT
3	BY MAKEUP VOLUME
4	BY CYCLE SETPOINT
5	BY MULTI-SETPOINT
6	CHANGE MY NAME
7	SCHEDULED LOCKOUT?

6.5.1.1 Disabled

The blowdown relay can be disabled. When a relay is disabled, it will not energize automatically.

- From the **RELAY OPTIONS** screen press “1” **Disabled** to disable the relay.

6.5.1.2 By Tower Setpoint

To set up the blowdown relay to operate based on a setpoint, select **BY TOWER SETPOINT**. The following screen will appear.

SETPOINT= 1000 μS
DEADBAND= 10 μS

6.5.1.2.1 SETPOINT

In the **SETPOINT** screen you will set the **SETPOINT**, the **DEADBAND** and the **BLOWDOWN TIMEOUT** alarm.

The **SETPOINT** is the Conductivity value that you are trying to maintain. Check with your water treatment engineer to determine the Conductivity setpoint for your system needs.

Follow these instructions to establish the controller's setpoint:

- Use the keypad numbers to enter the proper Conductivity setpoint and press “**ENT**”. When finished, you will automatically be moved down to the deadband.

NOTE: A high conductivity alarm will override this setpoint and force a blowdown to occur.

6.5.1.2.2 DEADBAND

After the setpoint is established, the controller's deadband must also be set. “**Deadband**” refers to the amount of conductivity above and below the setpoint—a range within which the controller will not react. Due to continuous fluctuations in the conductivity level, it is necessary to have this deadband range or stable readings will be difficult to maintain. The Deadband should be a small percentage of the setpoint. Half the deadband amount will be automatically put above the setpoint, and the other half below it.

For example, a conductivity setpoint of 1000 μS with a deadband of 20 μS would result in the relay turning on at 1010 μS and turning off at 990 μS .

- Use the keypad numbers to enter the proper deadband setpoint and press "ENT". When finished, you will automatically be switched to the **BLOWDOWN TIMEOUT** alarm screen.

6.5.1.2.3 BLOWDOWN TIMEOUT

The **BLOWDOWN TIMEOUT** alarm is designed to notify the operator of a problem in the blowdown system such as, a clogged strainer, or the blowdown valve failed to open. The **BLOWDOWN TIMEOUT** function will display a visual alarm on the display, but it will **NOT** turn off the relay. If a relay is configured as an alarm relay, the **BLOWDOWN TIMEOUT** alarm will energize the alarm relay. To disable this function set the **BLOWDOWN TIMEOUT** time to 0:00.

- Use the keypad numbers to enter the time in hours and minutes before this alarm will appear and press "ENT". Maximum setting is 17 hours and 59 minutes.

6.5.1.3 BY MAKEUP VOLUME

NOTE: For this configuration of the blowdown relay, MTR 1 is always assumed to be the makeup water meter and MTR 2 is assumed to be the blowdown water meter. Ensure that this is the case with your wiring or conductivity control will not function properly.

To program the blowdown to be based on volume, select "3" **BY MAKEUP VOLUME** in the **BLOWDOWN RELAY** screen. The following screen will appear.

BY MAKEUP VOLUME =====
1 FOR BLOWDOWN FLOW
2 FOR BLOWDOWN TIME

There are two methods available to blowdown based on volume, **FOR BLOWDOWN FLOW** and **FOR BLOWDOWN TIME**.

With **FOR BLOWDOWN FLOW**, the blowdown relay will be on until a specified amount of blowdown is met after a specified amount of make-up has been received.

With **FOR BLOWDOWN TIME**, the blowdown relay will be on for a specified amount of time after a specified amount of make-up has been received.

If **FOR BLOWDOWN FLOW** is selected:

- Use the keypad to enter the volume of makeup after which you want to blowdown then press "ENT"
- Input the volume of blowdown that you want to blow down then press "ENT".
- The next screen is the **BLOWDOWN TIMEOUT** screen. Enter the amount of blowdown time before the **EXCESS BLOWDOWN TIME ALARM** will occur then press "ENT". **This alarm will close the blowdown valve** and it will give an alarm indication on the display. The alarm time is set in hours and minutes. To disable this feature, enter "00:00".

If **FOR BLOWDOWN TIME** is selected:

- Use the keypad to enter the volume of makeup after which you want to blowdown then press "ENT".
- You will automatically be moved down to the amount of time to blow down in hours and minutes. Enter the amount of time to blowdown and press "ENT".

6.5.1.4 CHANGE MY NAME

The name of each individual relay can be changed to any 4-character name. This is useful to designate the chemical name for each relay. Use the arrow keys to change the character and the ENT key to move to the next character.

<p>OLD NAME= RLY2</p> <p>NEW NAME= INH</p>
<p><UP><DOWN>ENT: ACCEPT</p>

- From the **BLOWDOWN RELAY OPTIONS** screen press "4" **CHANGE MY NAME**.

6.5.1.5 SCHEDULED LOCKOUT?

This setting allows the user the choice of whether to lock out a relay during a scheduled feed sequence or not. If you do not want to lock out this relay during a scheduled feed sequence select **NO**.

<p>LOCK OUT RELAY DURING SCHEDULED FEED?</p> <p>=====</p> <p>1 * YES</p> <p>2 NO</p>

- From the **RELAY OPTIONS** screen press "5" **SCHEDULED LOCKOUT?**.
- Press "1" **YES** to lock out the relay during a scheduled feed or press "2" **NO** to allow the relay to operate normally during a feed schedule.

Note: This setting is only available and visible when the relay is set to operate based on **SETPOINT, WATER METER, or PERCENT of TIME.**

6.5.1.6 BLOWDOWN BY CYCLE SETPOINT

This option is only available if a conductivity node (NCON) is installed as the MAKEUP COND input.

If the NIN is installed with a conductivity node installed as the MAKEUP COND input the BLOWDOWN relay can be configured to blow down based on a cycle setpoint instead of a tower setpoint. The difference between the two is that a tower setpoint is a fixed conductivity value and does not change with a change in the makeup water conductivity. A cycle setpoint is the number of cycles of concentration of the cooling tower water that is desired and will adjust the actual tower setpoint automatically to maintain the cycles of concentration desired based on the makeup water conductivity. For example: If the tower setpoint is set to 1000 μ S, the controller will always try to maintain a reading of 1000 μ S in the cooling tower, no matter the value of the makeup water conductivity. If a cycle setpoint of 3.0 is set, the controller will always try to maintain a conductivity value in the cooling tower that is 3 times the current makeup water conductivity.

To set up the blowdown relay to operate based on a cycle setpoint, select **BY CYCLE SETPOINT**. The following screen will appear.

SETPOINT= 0.0
DEADBAND= 0.00

The setpoint is the number of cycles of concentration you want to maintain. The deadband is the number of cycles to use as the deadband. Refer to section 6.5.1.2.1, and 6.5.1.2.2, and 6.5.1.2.3 for a discussion on setpoint, deadband, and blowdown timeout.

- Use the keypad to enter a cycles of concentration setpoint. Press "ENT".
- Use the keypad to enter a deadband value. Press "ENT".
- Use the keypad numbers to enter the time in hours and minutes before the blowdown timeout alarm will appear and press "ENT". Maximum setting is 17 hours and 59 minutes.
- The next screen is the "**WHEN TO ACTIVATE**" screen. Select "1" **ABOVE SETPOINT** to turn on the blowdown relay when the conductivity rises above the cycles of concentration setpoint, or select "2" **BELOW SETPOINT** to turn on the blowdown relay when the conductivity falls below the cycles of concentration setpoint.

6.5.1.7 BY MULTI-SETPOINT

This option is only available if a conductivity node (NCON) is installed as the MAKEUP COND input.

If the NIN is installed with a conductivity node installed as the MAKEUP COND input the BLOWDOWN relay can be configured to blow down based on multiple setpoints instead of a single tower setpoint. There are three different setpoints that can be established based on the value of the makeup water conductivity.

The user programs three ranges of makeup water conductivity and a setpoint for each of the three ranges. The controller determines which of the three setpoints to use based on the conductivity of the makeup water conductivity.

When **BY MULTI-SETPOINT** is selected in the blowdown relay setup screen the **MULTI-SETPOINT** screen is displayed.

MULTI-SETPOINT	
=====	
1	SETPOINTS/RANGES
2	DEADBAND
3	BLOWDOWN TIMEOUT

- Press "1" **SETPOINTS/RANGES**

SETPOINTS / RANGES	
=====	
1	1000, 0000 - 0300
2	1500, 0300 - 0500
3	2000, 0500 - UP

- Establish a setpoint for three ranges of makeup water conductivity. The first range always starts at 0 μ S. The second range starts at the top of the first range. The third range is any conductivity above the second range.

Refer to section 6.5.1.2.1, and 6.5.1.2.2, and 6.5.1.2.3 for a discussion on setpoint, deadband, and blowdown timeout.

6.5.2 Configuring Relays 2,3,4,5,6,7,8

Below is the **RELAY OPTIONS** screen. The asterisk (*) next to one of the options tells you how that relay is configured. Relays 2, 3, and 4 can be programmed in each of the methods shown on the **RELAY OPTIONS** screen.

```
          RLY2
          =====
1*DISABLED
2 SETPOINT
3 WATER METER
4 PERCENT BLOWDOWN
5 PERCENT OF TIME
6 FEED SCHEDULE
7 ALARM RELAY
8 CHANGE MY NAME
9 SCHEDULED LOCKOUT?
```

6.5.2.1 Disabled

Relays 2, 3, and 4 can be disabled. When a relay is disabled, it will not energize automatically.

- From the **RELAY OPTIONS** screen press “1” **Disabled** to disable the relay.

6.5.2.2 By Setpoint

Relays 2, 3, and 4 can be configured to operate based on an ORP or conductivity setpoint.

To set up the relay to operate based on a setpoint, select **SETPOINT** in the RELAY OPTIONS screen. A screen asking **WHICH PROCESS?** will appear. Select ORP or conductivity. If conductivity is selected the following screen will appear.

```
          SETPOINT=
          1000 µs

          DEADBAND=
          20 µs
          PRO: +/-  ENT: ACCEPT
```

6.5.2.2.1 SETPOINT

In the **SETPOINT** screen you will set the **SETPOINT**, the **DEADBAND** and the **OVERFEED TIME** alarm.

The **SETPOINT** is the conductivity or ORP value that you are trying to maintain. Check with your water treatment engineer to determine the conductivity and ORP setpoints for your system needs.

Follow these instructions to establish the controller's setpoint:

- Use the keypad numbers to enter the proper ORP or conductivity setpoint and press "**ENT**". When finished, you will automatically be moved down to the deadband.

6.5.2.2.2 DEADBAND

After the setpoint is established, the relay's deadband must also be set. "**Deadband**" refers to the amount of conductivity or ORP above and below the setpoint—a range within which the controller will not react. Due to continuous fluctuations in the conductivity and ORP level, it is necessary to have this deadband range or stable readings will be difficult to obtain. The Deadband should be a small percentage of the setpoint. Half the deadband amount will be automatically put above the setpoint, and the other half below it.

For example, a Conductivity setpoint of 1000 μS with a deadband of 20 μS would result in the relay turning on at 1010 μS and turning off at 990 μS .

- Use the keypad numbers to enter the proper deadband setpoint and press "**ENT**". When finished, you will automatically be switched to the **OVERFEED TIME** alarm screen.

6.5.2.2.3 OVERFEED TIME

The **OVERFEED TIME** alarm is designed to notify the operator of a problem in the chemical feed system such as, a pump has lost its prime or there is no chemical in the drum. It will also protect the system from overfeeding chemical when the indicated conductivity or ORP does not display a change in actual conductivity or ORP. The **OVERFEED** timeout function will display a visual alarm on the display and **it will turn off the relay**. If a relay is configured as an alarm relay, the **OVERFEED TIME** alarm will energize the alarm relay. To disable this function set the **OVERFEED** time to 0:00.

- Use the keypad numbers to enter the time in hours and minutes before this alarm will appear and press "**ENT**". Maximum setting is 17 hours and 59 minutes.

6.5.2.2.4 WHEN TO ACTIVATE

After configuring the SETPOINT, the DEADBAND, and the OVERFEED alarm, the controller will automatically move to the **WHEN TO ACTIVATE** screen. To set up to feed chemical on a rising ORP or conductivity set the relay to activate *above* the setpoint. To set up to feed on a falling ORP or conductivity set the relay to activate *below* the setpoint.

```
WHEN TO ACTIVATE
=====
1 *ABOVE SETPOINT
2 *BELOW SETPOINT
```

- Select “1” **ABOVE SETPOINT** to turn on the relay when the ORP or conductivity rises above the ORP or conductivity setpoint, or select “2” **BELOW SETPOINT** to turn on the relay when the ORP or conductivity falls below the ORP or conductivity setpoint.

6.5.2.3 By Water Meter

Relays 2 through 8 can be configured to operate for a specified amount of time based on a specified amount of flow through the water meter inputs. **MTR1**, **MTR2** or the sum of **BOTH** water meter inputs can activate the relay.

- From the **RELAY OPTIONS** screen press “3” **WATER METER**.
- Select either **MTR1** or **MTR2** or **BOTH** as the trigger for the relay.
- Use the keypad to enter the amount of flow before the relay is activated. Press “ENT”.
- Enter the amount of time that the relay will be activated. Press “ENT”.

6.5.2.4 By Percent of Blowdown Time

Relays 2 through 8 can be activated by a percent of the time that the blowdown was on. The relay will activate after the blowdown shuts off. For example, if 50% is entered and the blowdown relay is on for 10 minutes, the relay will be energized for 5 minutes.

- From the **RELAY OPTIONS** screen, press “4” **PERCENT BLOWDOWN**.
- Use the keypad to enter a percent of blowdown time to activate this relay. Press “ENT”.

6.5.2.5 By Percent of Time

The Percent of Time feature allows you to feed chemical strictly based by a percent of time. This relay control scheme works in patterns of 20-second time blocks. A relay is on for some multiple of 20 seconds and off for some multiple of 20 seconds. Below is a chart showing some of the operation times for Percent of Time.

Percent	On Time	Off Time
1%	20 Sec	1980 Sec (33m)
5%	20 Sec	380 Sec (6m20S)
10%	20 Sec	180 Sec (3 m)
25%	20 Sec	60 Sec
33%	20 Sec	40 Sec
50%	20 Sec	20 Sec
66%	40 Sec	20 Sec
75%	60 Sec	20 Sec
90%	180 Sec (3 m)	20 Sec
95%	380 Sec (6m20S)	20 Sec
99%	1980 Sec (33m)	20 Sec

Note: In the case of “33%”, once every 66 minutes, the “off” time would extend an extra 20 seconds to make up for the accumulation of the odd % value vs. a 24 hour clock, since the percent of time is based on a 24HR clock in 20 second increments. The same could be said for the “66%” timer, except it will remain “ON” for the additional 20 seconds every 66 minutes.

To determine the total amount of chemical fed over a 24 hour period, multiply the percent of time by the number of hours a day that your controller is operating, then multiply by your chemical pump flow rate per hour.

For example:

We select 10% of the time, our controller operates 24 hours a day and our chemical pump flow rate is 1 gallon per hour.

$$10\% \times \frac{24 \text{ hours}}{\text{Day}} \times \frac{1 \text{ gallon}}{\text{Hour}} = \frac{2.4 \text{ Gallons}}{\text{Day}}$$

- From the **RELAY OPTIONS** screen press”5” **PERCENT OF TIME**.
- Use the keypad to enter the percentage of time desired. Press ”ENT”.

6.5.2.6 By Feed Schedule

The feed schedule is used to feed chemicals such as biocides on a time of day basis. Setting up the feed schedule is a two-part process. The first part is to configure the relay so that it will operate by feed schedule. The second part of the process is to configure the feed schedule. The feed schedule is covered in section 6.5.3.

- From the **RELAY OPTIONS** screen press "6" **FEED SCHEDULE**.

The controller will respond with the following screen.

SCHEDULED RELAY

SEE MAIN MENU
FOR FEED SCHEDULE

PRESS ANY KEY

The relay has been configured to operate based on a feed schedule but, the relay will not activate because the feed schedule has not been programmed yet.

6.5.2.7 As an Alarm Relay

Relays 2, 3, 4, 5, 6, 7, and 8 can be configured as alarm relays. The alarms that will cause the relay to activate are selectable from the controller alarms or from any node input alarms. The controller alarms include: **HIGH CONDUCTIVITY, LOW CONDUCTIVITY, FOULED CONDUCTIVITY SENSOR, SHORTED TC, OPENED TC, HIGH REFERENCE IMPEDANCE, HIGH REFERENCE VOLTAGE, LOW REFERENCE VOLTAGE, MAX BD TIME EXCEEDED, FEED SEQUENCE ACTIVE, RELAY TIME EXCEEDED** alarms, and the **NO FLOW** alarm.

- From the **RELAY OPTIONS** screen press "7" **ALARM RELAY**. The controller will respond with the following screen.

WHICH ALARMS?

=====

1 CONTROLLER
2 RELAYS 5-8
3 RELAYS 9-12
4 MAKEUP COND
5 REMOTE SENSOR
6 REMOTE SENSOR
7 REMOTE SENSOR
8 REMOTE SENSOR
9 ANALOG INPUTS (4)
10 ANALOG INPUTS (4)
11 DIGITAL INPUTS (4)
12 DIGITAL INPUTS (4)

- Select the alarms from this menu that will activate the relay.

6.5.2.8 Change My Name

The name of each individual relay can be changed to any 4-character name. This is useful to designate the chemical name for each relay. Use the arrow keys to change the character and the ENT key to move to the next character.

<p>OLD NAME= RLY2</p> <p>NEW NAME= INH</p>
<UP><DOWN>ENT: ACCEPT

- From the **RELAY OPTIONS** screen press "8" **CHANGE MY NAME**.

6.5.2.9 Scheduled Lockout?

This setting allows the user the choice of whether to lock out a relay during a scheduled feed sequence or not. If you do not want to lock out this relay during a scheduled feed sequence select **NO**.

<p>LOCK OUT RELAY DURING SCHEDULED FEED?</p> <p>=====</p> <p>1 * YES</p> <p>2 NO</p>

- From the **RELAY OPTIONS** screen press "9" **SCHEDULED LOCKOUT?**.
- Press "1" **YES** to lock out the relay during a scheduled feed or press "2" **NO** to allow the relay to operate normally during a feed schedule.

Note: This setting is only available and visible when the relay is set to operate based on **SETPOINT, WATER METER, PERCENT OF BLOWDOWN, or PERCENT of TIME**.

6.5.3 Setting up the Feed Schedule

Refer to section 6.5.2.5 to configure a relay to feed based on the feed schedule before continuing with this section.

To get to the feed schedule menu:

- From the **MAIN MENU** press "3" **FEED SCHEDULE**. You will see the following screen:

```
FEED SCHEDULE
=====
1*BY WEEKDAY
2 BY CYCLE CALENDAR
3 LIST SCHEDULE
```

The feed schedule can be programmed to feed chemicals by either **WEEKDAY** or by a **CYCLE CALENDAR** basis.

BY WEEKDAY is used to feed chemicals by the weekday name, i.e. Monday, Tuesday, Wednesday etc. This is a seven-day schedule. At the end of the week, the schedule starts over again. To configure the feed schedule to feed by weekday:

- From the **FEED SCHEDULE** screen, press "1" **BY WEEKDAY**.

BY CYCLE CALENDAR is used to feed chemicals by a schedule other than one that is seven days long. **BY CYCLE CALENDAR** can be used to feed the same chemical every day or up to 28 days between feedings. The operator specifies the number of days in the cycle calendar. After the cycle calendar is completed, the schedule starts over again. This method of feeding is particularly useful when feeding two biocides on alternating weekly basis. To configure the feed schedule to feed by cycle calendar:

- From the **FEED SCHEDULE** screen, press "2" **BY CYCLE CALENDAR**.
- Use the keypad to enter the number of days in your cycle then press "ENT". Remember the maximum number of days allowed is 28.
- Use the keypad to enter which day today is in your cycle, e.g. today is day number 5 in my 14 day cycle, then press "ENT".

After selecting whether the feed schedule will be fed by **WEEKDAY** or by **CYCLE CALENDAR** it is time to actually program the schedule. To enter the actual feed schedule or to edit the feed schedule from the feed schedule screen above:

- Press "3" **LIST SCHEDULE**. This will take you to a list of all scheduled feeds as shown in the screen on the next page.

NOTE: The maximum number of scheduled feeds is 16 (sixteen) total.

FEED SCHEDULE			
=====			
1	01	03:00	RLY2
2	00	00:00	
3	00	00:00	
4	00	00:00	
5	00	00:00	
6	00	00:00	

- If there are no scheduled feeds, select the first schedule and press "ENT". If you are editing the schedule, select the schedule that you want to edit and press "ENT".

Below is an example screen for programming a chemical feed. **Before programming a chemical feed, you need to configure Relay 2, 3, or 4 to be a feed schedule relay.**

RELAY (ARROWS): NONE
CYCLE DAY : 0
START TIME : 00:00
COND SETPOINT : 0
BLOW DURATION : 00:00
FEED DURATION : 00:00
LOCKOUT TIME : 00:00
<UP><DOWN>ENT: ACCEPT

- To program the schedule use the keypad to enter the values in the above screen. Press "ENT" to move to the next item.

NOTE: ALL TIMES ARE IN HOURS AND MINUTES

RELAY is which relay you want to program (you must configure a relay to be a feed schedule relay first). Use the arrow keys to select the available relays. Only relays that have been configured as feed schedule relays will appear.

CYCLE DAY or DAY is the day you wish to actuate the feed schedule relay.

START TIME is the time you want to start the feed schedule sequence. This start time uses the 24 hour clock or military time. **06:00:00** is 6 a.m. **18:00:00** is 6 p.m.

COND SETPOINT is a pre-bleed setpoint. This would typically be lower than the normal conductivity setpoint. Because the bleed valve may be disabled during a scheduled feed, a pre-bleed will help prevent a build up of tower conductivity. 0 μ S will disable this feature.

BLOW DURATION if the COND SETPOINT is not met within this time, the blowdown will stop and the feed schedule relay will be actuated. **If conductivity is disabled, this is the amount of time the controller will blow down during the pre-bleed sequence.** Inputting 0:00 will disable this feature. Lakewood Instruments recommends that some time be entered if pre-bleed is used.

FEED DURATION is the amount of time the feed schedule relay will be on.

LOCKOUT TIME after the feed duration is completed, an additional lockout time for all relays can be programmed. The lockout time prevents the other relays from operating until this time expires. **Setting this time to 0:00 will disable this feature.**

6.5.4 Alarms

The Model 2830e is equipped with both high and low conductivity and ORP alarms. This menu option allows you to program the specific values for these alarms. When a conductivity or ORP alarm is received, it will appear as a flashing message in the middle of the display and any configured alarm relays will be activated. **The high conductivity alarm will override the blowdown relay and force a blowdown to occur.** Consult your water treatment specialist when determining the proper High and Low Alarm values for your system.

To set the alarm setpoints:

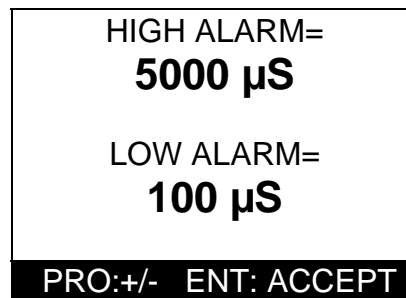

HIGH ALARM=
5000 µS

LOW ALARM=
100 µS

PRO:+/- ENT: ACCEPT

- From the **MAIN MENU** press "4" **ALARMS**. A screen asking **WHICH PROCESS?** will appear. Select ORP, ORP, or conductivity.
- Use the keypad to enter a value for the high alarm. Press "**ENT**".
- Use the keypad to enter a value for the low alarm and press "**ENT**".
- Use the keypad to enter a value for the deadband and press "**ENT**". Refer to section 6.5.1.2.2 for a discussion on deadband.

6.5.5 Water Meters

The 2830e series controllers will work directly with the following types of meters: dry contacting head meters, Seametrics open collector output meters, Signet 2535 and 2540 paddle wheel meters, and the Autotrol 1 inch and 2 inch meters. Contact Lakewood Instruments for other types of water meters.

Both water meter inputs are programmed in the same manner.

To get to the water meter configuration screen:

- From the **main menu**, press "5" **WATER METERS**. This will take you to the **WHICH WATER METER SCREEN**.
- Press "1" for **MTR1** or press "2" for **MTR2**.
- This will take you to the **WATER METER TYPES** screen as shown.

WATER METER TYPES	
=====	
1	CONTACTING HEAD
2	PADDLE WHEEL
3	DATA INDUSTRIAL
4	SIGNET
5	AUTOTROL TURB 1 IN.
6	AUTOTROL TURB 2 IN.
7	CHANGE MY NAME

- Use the keypad to select the type of water meter that you are using.

The next screen is the **UNITS OF VOLUME** screen.

- The water meters can be configured for gallons or liters. Press "1" for **GALLONS** or press "2" for **LITERS**.

If **CONTACTING HEAD** was selected:

- You will be taken to the **GALLONS OR LITERS PER CONTACT** screen. Use the keypad to enter the number of gallons or liters per contact for your specific meter then press "ENT". You will then be asked if you want to reset the total count for that meter to zero. Press "1" for **YES** or press "2" for **NO**.

If **PADDLE WHEEL** was selected:

- You will be taken to the **PULSES PER GAL/LITER** screen. Use the keypad to enter the pulses per gal/liter for your particular water meter then press "ENT". You will then be asked if you want to reset the total count for that meter to zero. Press "1" for **YES** or press "2" for **NO**.

If **DATA INDUSTRIAL** was selected:

- You will be taken to the **SLOPE VALUE** screen. Use the keypad to enter the K factor and offset values for your particular water meter then press "**ENT**". You will then be asked if you want to reset the total count for that meter to zero. Press "**1**" for **YES** or press "**2**" for **NO**.

If **SIGNET** was selected:

- You will be taken to the **K-FACTOR** screen. Use the keypad to enter the K-factor for your particular water meter then press "**ENT**". You will then be asked if you want to reset the total count for that meter to zero. Press "**1**" for **YES** or press "**2**" for **NO**.

If **AUTOTROL TURB 1 IN.** was selected:

- The controller will confirm that the **AUTOTROL TURB 1 IN.** has been selected and you will be asked if you want to reset the total count for that meter to zero. Press "**1**" for **YES** or press "**2**" for **NO**.

If the **AUTOTROL TURB 2 IN.** is selected:

- The controller will confirm that the **AUTOTROL TURB 2 IN.** has been selected and you will be asked if you want to reset the total count for that meter to zero. Press "**1**" for **YES** or press "**2**" for **NO**.

6.5.6 4-20 mA OUTPUTS

If the -35L option is ordered the model 2830e has two channels of 4-20 mA output. The -35L is an option card that can be added in the field.

6.5.6.1 Set Up of the 4-20 mA Output

To set up the 4-20 mA output:

- From the **Main Menu**, press "**6**" **4-20 mA OUTPUTS**

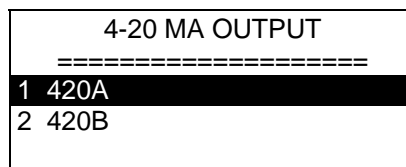

- Press "**1**" For **channel A** 4-20 mA OUT SETUP. Press "**2**" For **channel B** 4-20 mA OUT SETUP

The **4-20 mA Out Setup** screen allows the user to set the 4-20 mA range, calibrate the 4-20 mA output, select which process the 4-20 mA channel will respond to, take manual control of the 4-20 mA output, and change the name of the output. Below is the **4-20 mA Setup** screen.

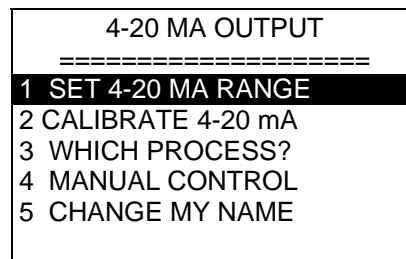

6.5.6.1.1 Set the 4-20 mA Range

The 4-20 mA output range must be set for the output to be useful.

- From the **4-20 mA Setup** screen, press **"1" Set the 4-20 mA RANGE.**
- Use the keypad to enter a conductivity or ORP value for the 4-mA point. Press **"ENT"**.
- Use the keypad to enter a conductivity or ORP value for the 20-mA point. Press **"ENT"**.

6.5.6.1.2 Calibrate

The 4-20 mA needs to be calibrated to the actual output to be accurate. A milliamp meter is necessary to calibrate the 4-20 mA output. Connect the milliamp meter in-line with one leg of the 4-20 mA output. Refer to the drawing in the back of this manual for wiring instructions.

- From the **4-20 mA Setup** screen, press **"2" CALIBRATE.**
- Use the keypad to enter the milliamp reading from the milliamp meter for the **4-mA** point. Press **"ENT"**.
- Use the keypad to enter the milliamp reading from the milliamp meter for the **20-mA** point. Press **"ENT"**.

6.5.6.1.3 Which Process?

The two channels of 4-20 mA output can be configured to ORP or conductivity, or if the model 2830e has any remote sensor nodes attached, the 4-20 mA channel can be configured to operate based on that input.

- From the **4-20 mA Setup** screen, press **"3" WHICH PROCESS?.**
- Use the up and down arrow keys to select the process that will control that channel of 4-20 mA output. Press **"ENT"**.

6.5.6.1.4 Manual Control

Manual control is used to temporarily change the 4-20 mA output.

- From the **4-20 mA Setup** screen, press **"4" MANUAL CONTROL**.
- Use the up and down arrow keys to raise or lower the 4-20 mA output. To exit this screen press **"CLR"**.

6.5.6.1.5 Change My Name

The name of the 4-20 mA output can be changed by the operator.

- From the **4-20 mA Setup** screen, press **"5" CHANGE MY NAME**.
- Use the arrow keys to change the characters, use the ENT key to move the cursor to the next character.

6.5.7 The System Setup Menu

The system setup menu is used to set up the temperature compensation, damping, initialize the controller, digital inputs, check the firmware version, change the security passwords, check the diagnostics, set up the communications, change the process names, and node installation.

6.5.7.1 Process Parameters

There are sub-screens in the process parameter screen for each of the process inputs. For the model 2830e there is a screen for each of ORP, conductivity, and any nodes that may be installed.

For conductivity and ORP, the process parameters screen is used to change the name of the conductivity or ORP process.

The name of the process can be changed from **ORP** or **COND** to a different 4-character name.

To change the name of the process:

- From the Main Menu press **"7" SYSTEM SETUP**.
- Press **"1" PROCESS PARAMETERS**. Select **ORP** or **Cond**
- Use the arrow keys to change the characters, use the ENT key to move the cursor to the next character.

6.5.7.2 Initialization

Initialization restores the factory default settings to the controller. The whole controller can be initialized or just the calibration. It is suggested that you initialize the whole controller before you program the controller. This will clear any random settings that may be in the controller. To do so, follow these instructions:

- From the **Main Menu**, press **"7" SYSTEM SETUP**.
- Press **"2" INITIALIZATION**.
- Press **"2" WHOLE CONTROLLER** and press **"ENT"**. A warning will appear on the screen (see below). Press **"1"** to proceed, **"2"** to cancel.

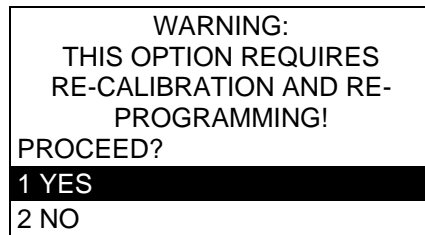

To initialize just the calibration:

- Press **"1" CALIBRATIONS** instead of **"2" WHOLE CONTROLLER** in the procedure above. Select ORP or conductivity. The same warning screen will appear.

6.5.7.3 Digital Inputs

If the model 2830e controller has a digital input node (NDIG) installed the inputs are configured from this screen. If a NDIG is not installed there is no access to this menu item. Configuration of the digital inputs are covered in the NDIG manual.

6.5.7.4 Firmware Versions

Sometimes it is necessary to verify the firmware version of the controller for troubleshooting purposes. To obtain the firmware versions:

- From the **Main Menu**, press **"7" SYSTEM SETUP**.
- Press **"4" FIRMWARE VERSION**.
- The firmware versions will be displayed. Use the arrow keys to see all firmware versions. To exit this screen, press **"CLR"**.

6.5.7.5 Change the Security Passwords

The security password can be changed from the factory default settings to any four-digit value of your choice.

To change the security passwords:

- From the **Main Menu**, press "7" **SYSTEM SETUP**.
- Press "5" **SECURITY**.

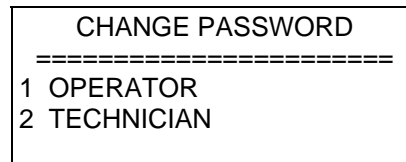

- Press "1" **OPERATOR** to change the operator password or Press "2" **TECHNICIAN** to change the technician password.
- Use the keypad to enter the old password. If the password has not been changed before, the old password for **OPERATOR** is **1111** and the password for **TECHNICIAN** is **2222**.
- Use the keypad to enter the new password.
- Use the keypad to enter the new password a second time for verification

If you lose your password, contact Lakewood Instruments for assistance.

6.5.7.6 Diagnostics

The diagnostics screen is used for troubleshooting purposes. Contact Lakewood Instruments for assistance.

6.5.7.7 Communications

The model 2830e has an option for remote communications, the –RS2L option. If this option is installed the communications option is configured from this screen. This screen is used to set up the com port, initialize the modem, and set the remote password.

To set up the communications option:

- From the **Main Menu**, press "7" **SYSTEM SETUP**.
- Press "7" **COMMUNICATIONS**.

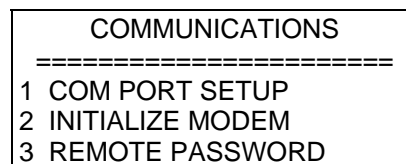

6.5.7.7.1 Com Port Setup

Com port setup is used to set up the com port for use with a modem or direct connect.

- To set up the com port press “1” **COM PORT SETUP**

```
COM PORT PARAMETERS
=====
BAUD RATE:  19200
DATA BITS:  8
STOP BITS:  1
PARITY      :  NONE
<UP><DOWN> ENT: ACCEPT
```

- Use the arrow keys to change the baud rate. If using the direct connect method of communicating, ensure that the baud rate at the controller and the baud rate in the LRWS software match.
- The standard values for the **DATA BITS** is 8, **STOP BITS** is 1, and **PARITY** is NONE. Normally these will not need to be changed.

6.5.7.7.2 Initialize Modem

Before a modem can be used by the controller it must be initialized. The initialization screen gives four choices of modems.

To initialize the modem:

- From the Communications menu, press “2” **INITIALIZE MODEM**

```
INITIALIZE MODEM
=====
1 HAYES ACCURA
2 U.S. ROBOTICS
3 ZOOM
4 OTHER MODEM
```

- Select your modem from the list. If your modem is not listed and you select **OTHER MODEM** use the keypad to enter the initialization string for your modem.
- If the modem fails to initialize, check the 25-pin connector, the ORPone cable, the modem, and the –RS2L option card.

6.5.7.7.3 Remote Password

Remote communications to the Lakewood Instruments 2000 series controllers is protected with an 8-digit password. The remote password is required to make changes to the model 2830e controller using the communications option card.

The remote password screen in the communications menu is used to change the remote password. The remote password can only be changed at the controller.

To change the remote password:

- From the communications menu, press “**3**” **REMOTE PASSWORD**.
- Use the keypad to enter the old password. Enter the new password. Repeat the new password again for verification. **NOTE: The default password is 12345678.**
- Set the remote password in the LRWS program to match the new password for this controller.

6.5.7.8 Node Installation

The node installation menu is used to install new nodes and to de-install installed nodes. The model 2830e already includes one NRLY preinstalled at the factory. Please refer to your node manual for information on node installation.

6.5.8 Setting the Clock

The clock uses the 24 hour or military time. **06:00:00** is 6 a.m. **18:00:00** is 6 p.m. To set the clock:

- From the **Main Menu** press “**8**” **CLOCK**. The following screen will appear:

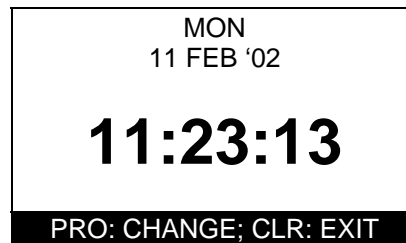

- Press “**PRO**” to change the clock settings.
- Use the up and down arrow keys to change the day of the week. Press “**ENT**”.
- Use the number keys to change the date. Press “**ENT**”.
- Use the arrow keys to change the month. Press “**ENT**”.
- Use the number keys to change the year. Press “**ENT**”.
- Use the number keys to change the hour. Press “**ENT**”.
- Use the number keys to change the minutes. Press “**ENT**”.
- Use the number keys to change the seconds. Press “**ENT**”.
- Press “**CLR**” to exit this screen.

You must press “**ENT**” all the way through this menu for the settings to take affect.

6.5.9 Changing the Security Levels

The security level can be change to prevent any unwanted tampering of the controller. To change the security level from **Technician** to **Operator** or **View-Only**:

- From the **Main Menu**, press “0”. (*Note that “0” does not appear on the menu screen.*)

CHANGE LEVEL TO OPERATOR ? WARNING:YOU SHOULD KNOW THE PASSWORD. 1 YES 2 NO

- Select **YES** to change the security level to a more restrictive level.

The controller menu now functions at the new security level.

To return to the **Technician** security level:

- Press the numeric password from the **Process** screen:

TECHNICIAN PRESS ANY KEY

Remember that following the first power-up the Technician password is 2222 and the Operator password is 1111. You may change the passwords in the SYSTEM SETUP menu.

7.0 Maintenance

Periodic maintenance is required to ensure trouble free operation of the model 2830e controller. The following sections cover the required maintenance.

7.1 Sensor Maintenance

Routine maintenance is necessary in order to maximize the efficiency and accuracy of your sensor.

7.1.1 Conductivity Sensor

Clean the electrode end of the Conductivity sensor at least once per month. Cleaning of the Conductivity sensor may need to be performed more frequently if it is in a high fouling environment.

- Remove power from the controller and shut off the sample flow.
- Remove the sensor from its plumbing.
- Clean the electrodes with a wire brush. A soft steel brush is preferable over a brass brush. Do not use cloth to clean the electrodes. Cloth has oils that will foul the sensor.
- If there is oil on the sensor glass, use isopropyl alcohol to clean the electrode.
- It is recommended that you use a 10% Muriatic or HCL acid to clean the sensor if necessary.
- Wash the sensor off with tap water.
- Install the sensor in its plumbing.
- Restore sample flow and check for leaks.
- Restore power to the controller.
- Perform a calibration of the Conductivity.

7.1.2 ORP Sensor

Clean the electrode end of the ORP sensor at least once per month. Cleaning of the ORP sensor may need to be performed more frequently if it is in a high fouling environment.

- Remove power from the controller and shut off the sample flow.
- Remove the sensor from its plumbing.
- Be careful not to touch the glass electrode. Do not use cloth to clean the electrode. Cloth has oils that will foul the sensor.
- If there is oil on the sensor glass, use isopropyl alcohol to clean the electrode.
- It is recommended that you use a 10% Muriatic or HCL acid to clean the sensor.
- Wash the sensor off with tap water.
- Install the sensor in its plumbing.
- Restore sample flow and check for leaks.
- Restore power to the controller.
- Allow the reading to stabilize for approximately 30 minutes.
- Perform a calibration of the ORP.

7.2 Flow Switch Maintenance

If you have the flow switch plumbing assembly, you may need to periodically clean the wetted parts in this assembly.

- Shut off the inlet flow and the power to the controller.
- Turn the red lock ring for the flow switch counterclockwise.
- Pull out the clear flow sight tube and remove the float with your fingers.
- Use a bottlebrush on the float, flow sight and the flow switch assembly to remove any residue.
- Clean and lubricate the “O” ring with a silicone-based lubricant (petroleum-based lubricants will cause the O-ring to swell).
- Lock down the red lock ring after you replace the components.
- Turn the inlet flow back on and check for leaks.

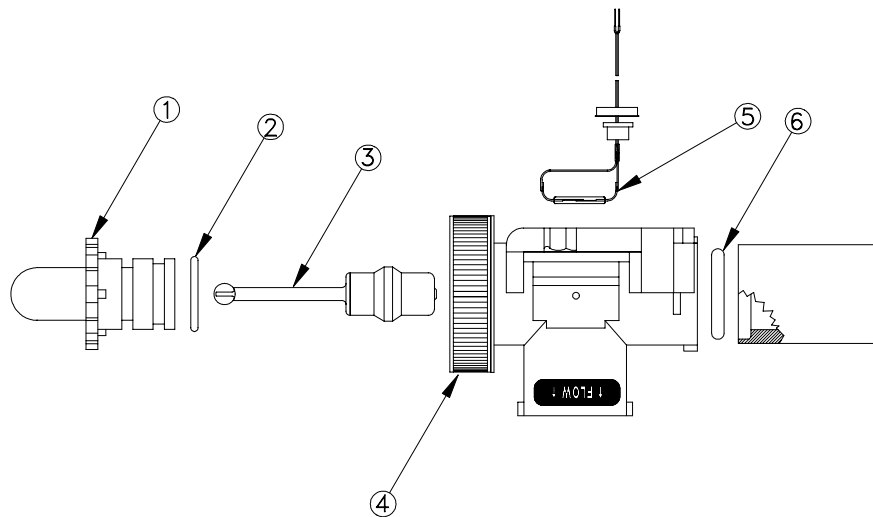

FlowSwitch Assembly

Find No.	Part No.	Part Description
1	1167266	Flowsight
2	1166418	O-Ring (flow sight)
3	1167234	Flow Magnet
4	1169740	Red Locking Ring Kit
5	1107004	Reed Switch
6	1166417	O-Ring (check valve)

7.2.1 Replacing the Reed Switch

If you ever need to replace the reed switch for the flow switch, follow the procedure below.

- Remove the power to the controller and shut off the sample flow.
- Disconnect the flow switch wires from the controller.
- Remove the screws holding the flow switch plumbing assembly and disconnect flow switch assembly from piping, if necessary to gain access to the reed switch.
- Pull hard on the wires that go to the reed switch assembly to remove the reed switch from the plumbing assembly.
- Push the new reed switch into the plumbing assembly and wire the new reed switch to the controller.
- Re-install plumbing.
- Restore flow to the plumbing assembly and check for leaks.
- Restore power to the controller.

7.3 Replacing the Fuses

The Model 2830e contains two 10A, 250V fuses. The fuse holders are located on the bottom of the enclosure. They are accessible from the outside of the box. Replacement fuses must be a fast blow type. If a fuse is blown, the display may be blank and the four power supply lights inside the controller enclosure may be dark when the unit is connected to power or there will be no power out of relays 5 through 8. Refer to the troubleshooting section of this manual for more information about blank displays.

8.0 Troubleshooting

8.1 Error Messages

This section discusses some of the more common questions with the Model 2830e. These notes are not intended to be all-inclusive—only to cover the most common situations. If you have other questions or are need support, contact the Lakewood Instruments Technical Service Department toll free at (800) 228-0839.

PROBLEM	WHAT THIS MEANS	CORRECTIVE ACTION
{Alarm Flashing} “Conductivity: HIGH ALARM”.	Conductivity is too high with respect to the high alarm setpoint.	<ol style="list-style-type: none"> 1. Check the High Alarm Value. 2. Check relay setpoints and deadbands. 3. Check operation of bleed-off valve. Use the manual relay control to help. 4. Check blowdown valve is not stuck closed or the line is restricted.
{Alarm Flashing} “Conductivity: LOW ALARM”.	Conductivity is too low with respect to the low alarm setpoint.	<ol style="list-style-type: none"> 1. Check the Low Alarm Value. 2. Check relay setpoints and deadbands. 3. Check blowdown valve is not stuck open. 4. Check that the system is not overflowing.
Water meters not accumulating.	<p>There may be a problem with the wiring or the reed switch in the meter may be bad.</p> <p>For water meters other than the contacting head type, check the manufacturer’s user manual for that particular water meter.</p>	<ol style="list-style-type: none"> 1. Approximately 24 volts DC should be present at the input terminal when the water meter contact is closed. That should change to zero VDC when the contact opens. Check these voltages and for correct wiring. 2. Is the controller configured for your type of water meter?
{Alarm Flashing} “FEED SEQUENCE ACTIVE”.	This simply indicates that a feed schedule relay is active.	No action necessary.
Display is blank.	There may be a problem with the incoming power, the fuse or the circuit board. Open the front panel to troubleshoot.	<ol style="list-style-type: none"> 1. Check the fuse. Replace if blown. 2. Does the unit have power? Verify with volt meter. 3. If there is power to terminals LINE and NEUTRAL on TA, call Lakewood Instruments Technical Service for more information.

PROBLEM	WHAT THIS MEANS	CORRECTIVE ACTION
<p>{Alarm Flashing} “RLY: TIME EXCEEDED”.</p>	<p>This indicates that the controller has been trying to feed chemical for longer than the user-programmed time and is unable to reach the setpoint.</p>	<ol style="list-style-type: none"> 1. Check for proper operation of pump or valve. Use the manual relay control to help. 2. Check that the chemical drum is not empty. 3. Check for power to the chemical pump. 4. Verify the relay timeout time is properly set for your application (see RELAYS in MAIN menu). 5. To reset this alarm, momentarily turn off flow to the controller to get the no flow alarm.
<p>“NO FLOW” alarm.</p>	<p>Flow input switch is not closed.</p>	<ol style="list-style-type: none"> 1. The flow switch float may be stuck or no flow is present. 2. Flow switch may be bad. Replace reed switch in plumbing assembly. 3. If no flow switch is used, a jumper wire should be installed across the flow switch input. Removing the jumper disables all relay outputs.
<p>Bleed valve relay is closed above setpoint.</p>	<p>Controller may be in biocide schedule.</p>	<p>Check feed schedule.</p>
<p>Bleed valve relay is open below setpoint.</p>	<p>High conductivity alarm will force the bleed valve to open. Controller may be doing a pre-bleed before feeding biocide.</p>	<ol style="list-style-type: none"> 1. Check High conductivity alarm setpoint. Change setpoint if necessary. 2. Check feed schedule. Adjust as necessary.
<p>“SENSOR READS ZERO”</p>	<p>You are trying to perform a span calibration of the conductivity and the conductivity sensor reads zero.</p>	<ol style="list-style-type: none"> 1. Check wiring. 2. Ensure sensor is full immersed in water. 3. The model 2830e for cooling towers will not accept a span calibration below about 200 μS. Cycle conductivity higher and re-calibrate.

PROBLEM	WHAT THIS MEANS	CORRECTIVE ACTION
{ALARM FLASHING} “COND:Fouled SENSOR”	Conductivity sensor is not reading properly.	<ol style="list-style-type: none"> 1. Clean sensor. 2. Check wiring. Verify that all connectors are fully mated. 3. Replace conductivity sensor.
{Alarm Flashing} “ORP: HIGH ALARM”.	ORP is too high with respect to the high alarm setpoint.	<ol style="list-style-type: none"> 1. See {RLY: TIME EXCEEDED}. 2. Check the High Alarm Value. 3. Check relay setpoints and deadbands. 4. Check chemical drum levels. 5. Check proper operation of chemical pumps.
{Alarm Flashing} “ORP: LOW ALARM”.	ORP is too low with respect to the low alarm setpoint.	<ol style="list-style-type: none"> 1. See {RLY: TIME EXCEEDED}. 2. Check the Low Alarm Value. 3. Check relay setpoints and deadbands. 4. Check chemical drum levels.

9.0 Factory Service

-  Technical Support for Lakewood Instruments can be reached by calling (800) 228-0839 or faxing (414) 355-3508, Monday through Friday, 7:30 a.m. – 5.00 p.m. CST.

NOTE: IF YOU CALL FOR TROUBLESHOOTING HELP, PLEASE HAVE THE MODEL NUMBER, SERIAL NUMBER, AND ANY OPTIONS PERTAINING TO YOUR UNIT AVAILABLE FOR REFERENCE.

-  Mail and returns should be sent to:

**Lakewood Instruments
7838 North Faulkner Road
Milwaukee, WI 53224 USA**

When any merchandise is to be returned to the factory, please call and obtain a Return Goods Authorization (RGA) number and have the following information available:

- Customer's name, address, teleORPone and fax numbers (shipping and billing).
- A hard copy purchase order number for cases where repairs or parts are required that are not under warranty.
- A contact person's name and teleORPone number to call if the equipment is beyond repair or to discuss any other warranty matter.
- Equipment model and serial numbers.
- Reason for return, e.g., repair, warranty, incorrect part, etc.

We will then fax to your attention an RGA form that must accompany the returned item.

NOTE: THE RGA NUMBER MUST BE CLEARLY WRITTEN ON THE OUTSIDE OF THE PACKAGE(S) BEING RETURNED.

**ANY ITEMS SENT BACK TO THE FACTORY
WITHOUT AN RGA NUMBER WILL BE REFUSED
AND RETURNED TO SENDER**

Parts List and Service Guide

When calling Lakewood Instruments, please have your controller's complete model number and serial number available, together with the firmware version so that the Technician can better assist you.

Refer to the Ordering Information section of this manual for part numbered replacement parts.

Write your controller's complete model number, serial number, and firmware version here so that you will have them available if you wish to contact a Lakewood Instruments technician.

Model Number:

Serial Number:

Firmware Version:

10.0 Drawings

NOTES: UNLESS OTHERWISE SPECIFIED;

REVISIONS			
REV	DESCRIPTION	DATE	APPROVAL
A	ECO 10M42	PSG 2-1-07	

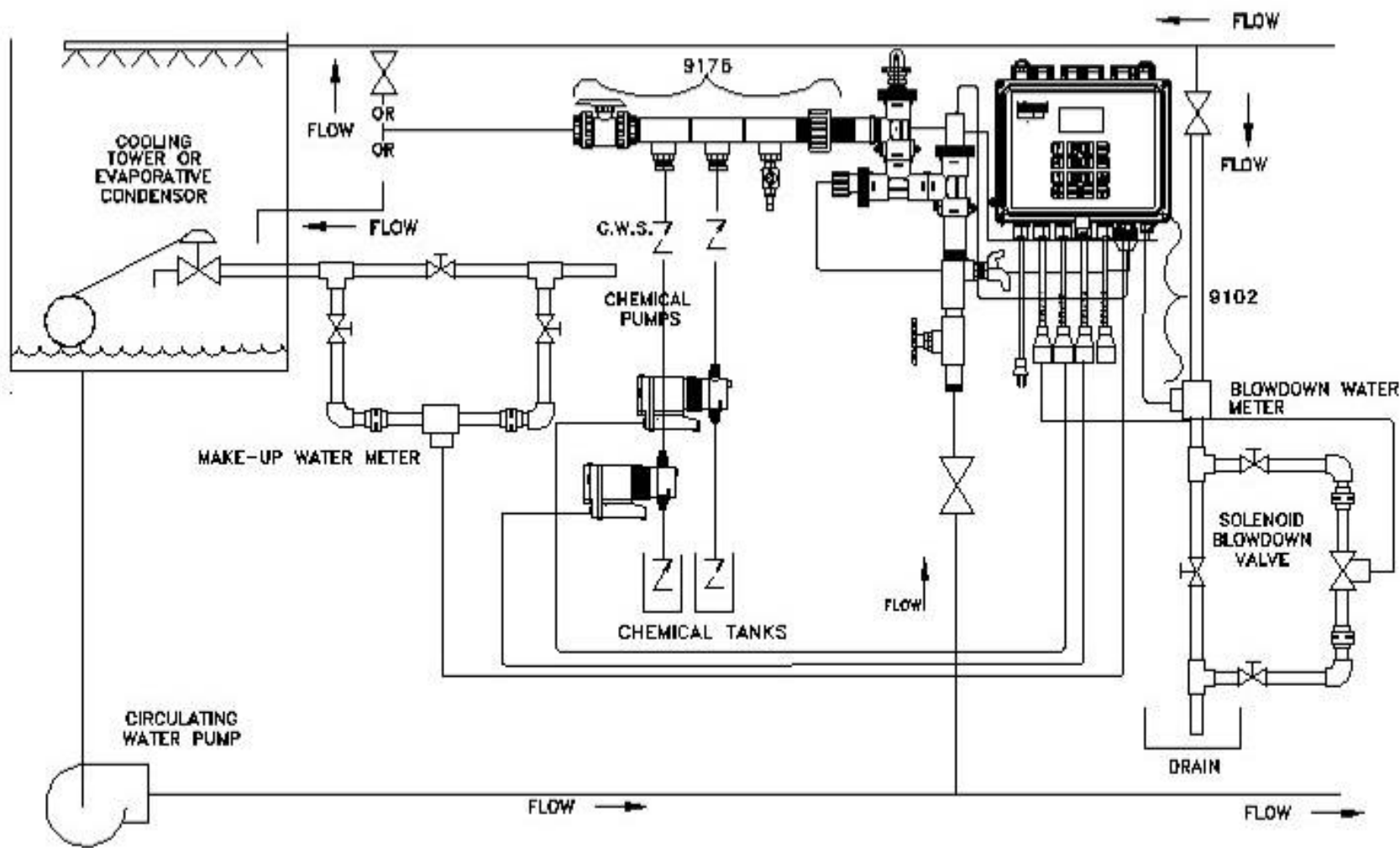

		RECOMMENDED INSTALLATION COOLING TOWER CONTROL SYSTEM SERIES 2400e	
NEXT ASSEMBLY APPLICATION NO.	PKG. QTY. 1	DATE 11/15/07	PART NO. 1268649_2a
NONE		NONE	
1 OF 1			

REVISION HISTORY					
REV	DESCRIPTION	EGG	DWN	DATE	APVD
A	IN ACCORDANCE WITH EGG	1034E	PSB	2-1-07	

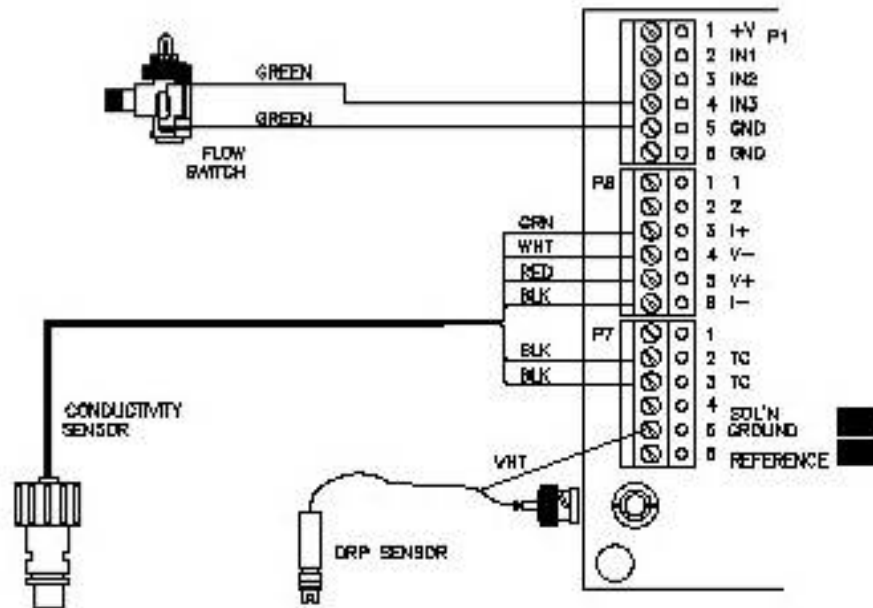

NOTICE ON REPRODUCTIONS
 THE DRAWING, THE DESIGN AND THE DATA ON IT ARE THE PROPERTY OF
 LAKWOOD INSTRUMENTS. IT IS TO BE USED ONLY BY THE PERSONS
 AUTHORIZED BY LAKWOOD INSTRUMENTS. IT IS NOT TO BE REPRODUCED,
 COPIED, OR TRANSMITTED IN ANY FORM OR BY ANY MEANS, ELECTRONIC OR
 MECHANICAL, INCLUDING PHOTOCOPYING, RECORDING, OR BY ANY INFORMATION
 STORAGE AND RETRIEVAL SYSTEM.

MATERIAL	FRAC	DESCRIPT	AMOUNT
		5/8" T	
		.002 ± .05	
	35/16	.002 ± .010 ± .5'	

ORDER NO.	DWN	PSB	DATE
			2-1-07

CUSTOMER	DATE

CUSTOMER LOC.	APVD	DATE

DO NOT SCALE



TITLE			
WIRING DIAGRAM SENSOR WIRING, LOW POWER M-2430e			
SIZE	DATE	DWG NO/REV	REV
B		1268628_2a	A
SCALE	FILE TYPE	SHEET 1 OF 1	
1:1	DWG		

FOR DATA REVIEW PLEASE

NOTES: UNLESS OTHERWISE SPECIFIED;

- ① 2450: CANNOT BE USED WITH CONTACTING HEAD METER.
- ② 2450: METER 1 IS PERMEATE, METER 2 IS CONCENTRATE.
- ③ CUSTOMER SUPPLIED, 10K RESISTOR (PULL-UP).
- ④ ONLY OPEN COLLECTOR OUTPUT WATER METERS MAY BE USED.

REVISION HISTORY						
REV	DATE	DESCRIPTION	BY	APP	DATE	APP
A		RELEASE	11/1	EV	2/25/97	
B		RELEASE	12/1	EV	9/24/97	
D		RELEASE	12/7	EV	10/3/97	
D		RELEASE	14/8	EV	11/2/97	-JES
E		ADDED MTR 3	19/1	EV	2/11/98	-JES
F		REWORK HEAD, 93ND BOARD	17/3	EV	2/11/98	

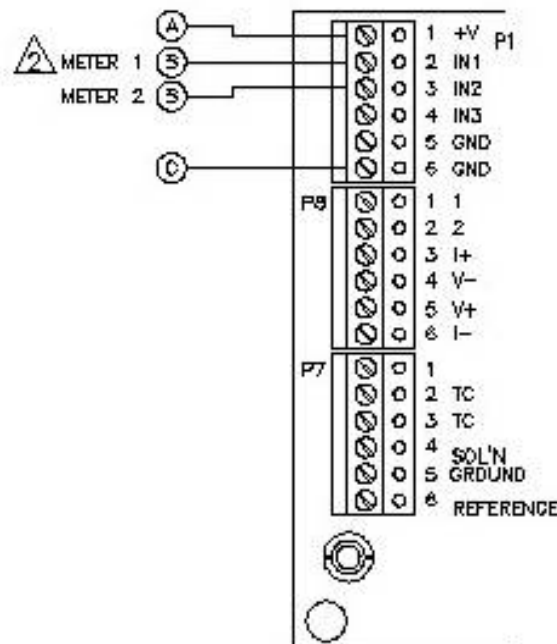
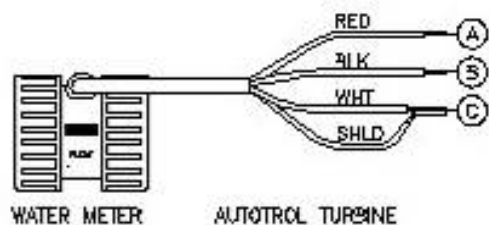
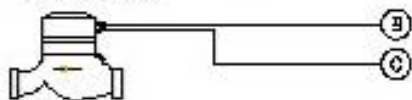

① CONTACTING HEAD TYPE WATER METER

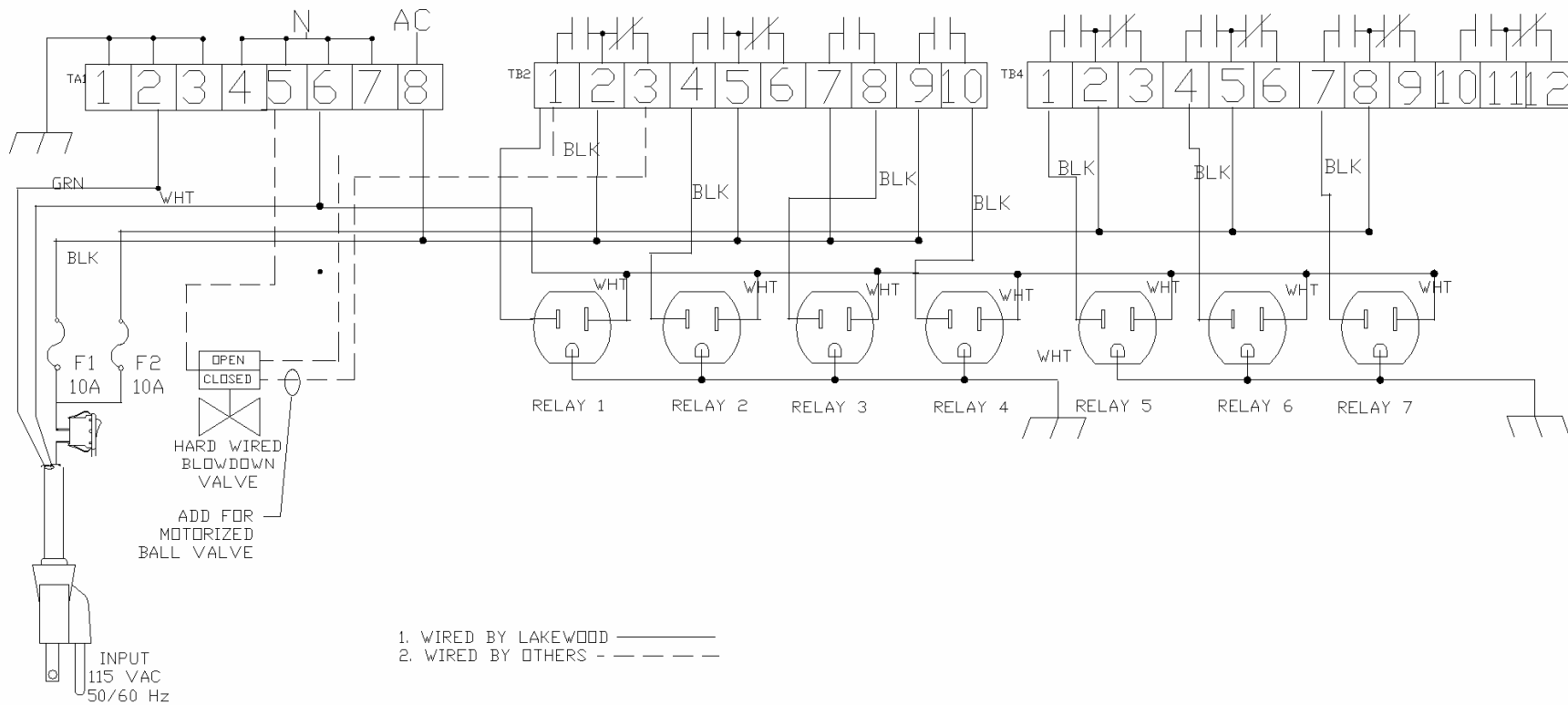

<p>LIST OF SUBSTITUTIONS</p>				<p>Lakewood INSTRUMENTS</p>	
<p>DATE: 11/1/97</p> <p>BY: EV</p> <p>APP: EV</p> <p>DATE: 2/25/97</p>	<p>REV: 1</p> <p>DATE: 2/25/97</p>	<p>DATE: 12/7/97</p> <p>BY: EV</p> <p>APP: EV</p> <p>DATE: 10/3/97</p>	<p>DATE: 11/2/97</p> <p>BY: EV</p> <p>APP: EV</p> <p>DATE: 11/2/97</p>	<p>DATE: 2/11/98</p> <p>BY: EV</p> <p>APP: EV</p> <p>DATE: 2/11/98</p>	<p>DATE: 2/11/98</p> <p>BY: EV</p> <p>APP: EV</p> <p>DATE: 2/11/98</p>
<p>WATER METER INPUTS, W-2000 SERIES</p>			<p>1109544-24</p>		
<p>DO NOT SCALE</p>		<p>SCALE</p>		<p>SCALE</p>	

REVISION		REVISION HISTORY			
DWG	PART	DESCRIPTION	ECO	DWN/DATE	APVD/DATE
A	A	RELEASE	10116	PSG 10-7-09	



NOTICE ON REPRODUCTIONS											
<small>THIS DRAWING, THE DESIGN AND THE PATENTS IT COVERS ARE THE PROPERTY OF LAKEWOOD INSTRUMENTS LLC. THEY ARE LOANED MERELY ON THE BORROWERS EXPRESS AGREEMENT THAT THEY WILL NOT BE REPRODUCED, COPIED, LOANED, EXHIBITED, NOR USED EXCEPT IN THE LIMITED WAY AND THE PRIVATE USE PERMITTED BY WRITTEN CONSENT GIVEN BY THE LENDER TO THE BORROWER</small>											
DIMENSIONING AND TOLERANCING PER ASME Y14.5M-1994											
MATERIAL		TOLERANCES UNLESS NOTED		TITLE							
		DECIMALS .X ± .XX ± .XXX ± ANGLES ±		WIRING DIAGRAM, 2800e SERIES NEMA ENCLOSURE							
FINISH		DWN	PSG	DATE	10-7-09	SIZE	 THIRD ANGLE	PN	1269031	REV	A
		CHKD		DATE		A					
PROJECT:		APVD		DATE		SCALE	SHEET 1	DWG NO	1269031_3a	REV	A
LIBRARY:		VERSION				NTS					

NOTES: UNLESS OTHERWISE SPECIFIED:
 ⚠ STANDARD FOUR CONDUCTOR TELEPHONE CABLE
 UP TO 50 FEET IN LENGTH MAY BE SUBSTITUTED.

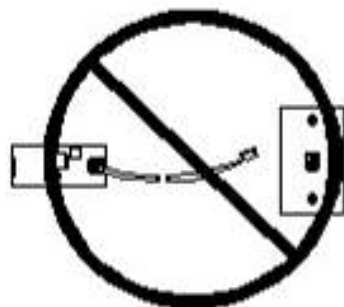
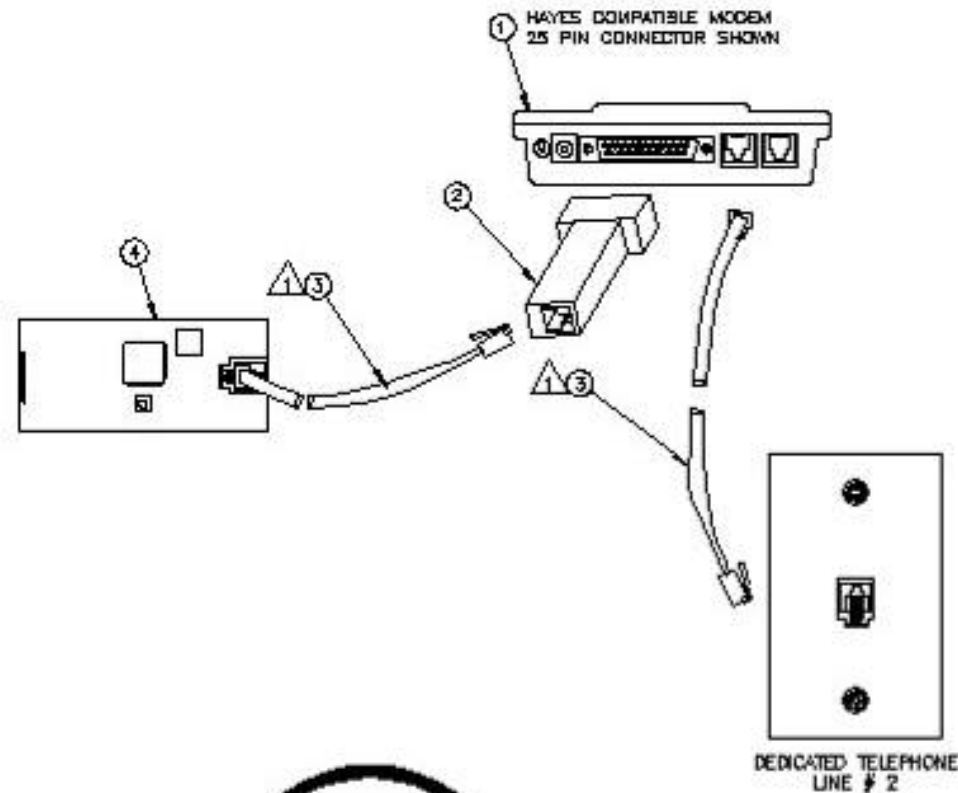

DO NOT PLUG RSL DIRECTLY INTO TELEPHONE LINES

REVISION HISTORY						
REV	DATE	DESCRIPTION	ISS	DES	CHK	APPD
A		ISSUED	CHT	MLM	VJM	
B		DESIGN	ERT	MLM	L/RS	
C		REVISED	CHT	ML	TS/L/ST	
D		REVISED	WRT	ML	TS/L/ST	LSB

PERSONAL COMPUTER WITH MODEM

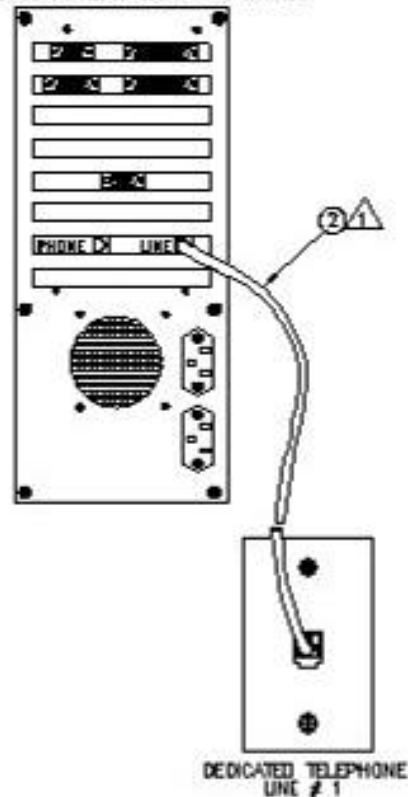

1	PCB	PCB, COM MODE	ASSEMBLED PCB, 1A-2000	4
1	66336	CABLE, RMT, 25 FT.		3
1	67765	ADAPTER	25 P MALE D CONN TO RJ11 DTE	2
1	67740	MODEM	HAYES COMPATIBLE	1

WORK IN PROGRESS			
GENERAL		DATE	
DATE	TIME	FILE	INSTALLATION LAYOUT
WORK NO.	JOB NO.	REV	COMMODE TO 25P DTE, SER 2000, RECD
DESIGNED	CHKD	BY	1103706-1d
APPROVED	REV	BY	REV D
RD 1627 SCALE	REV	BY	REV D

Labradore
 INSTRUMENTS

NOTES: UNLESS OTHERWISE SPECIFIED;

1. STANDARD FOUR CONDUCTOR TELEPHONE CABLE UP TO 50 FEET IN LENGTH MAY BE SUBSTITUTED.

REVISION HISTORY					
REV	DATE	DESCRIPTION	ENR	REV	DATE
A	08/28/82	RELEASE	1367	07	10/2/87
B		REWORK	1367	07	10/2/87
B		REWORK	1448	07	11/14/87

PERSONAL COMPUTER WITH MODEM

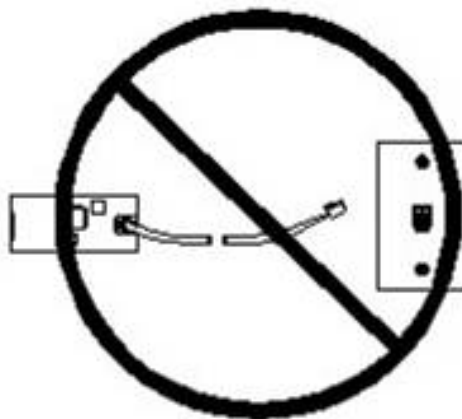
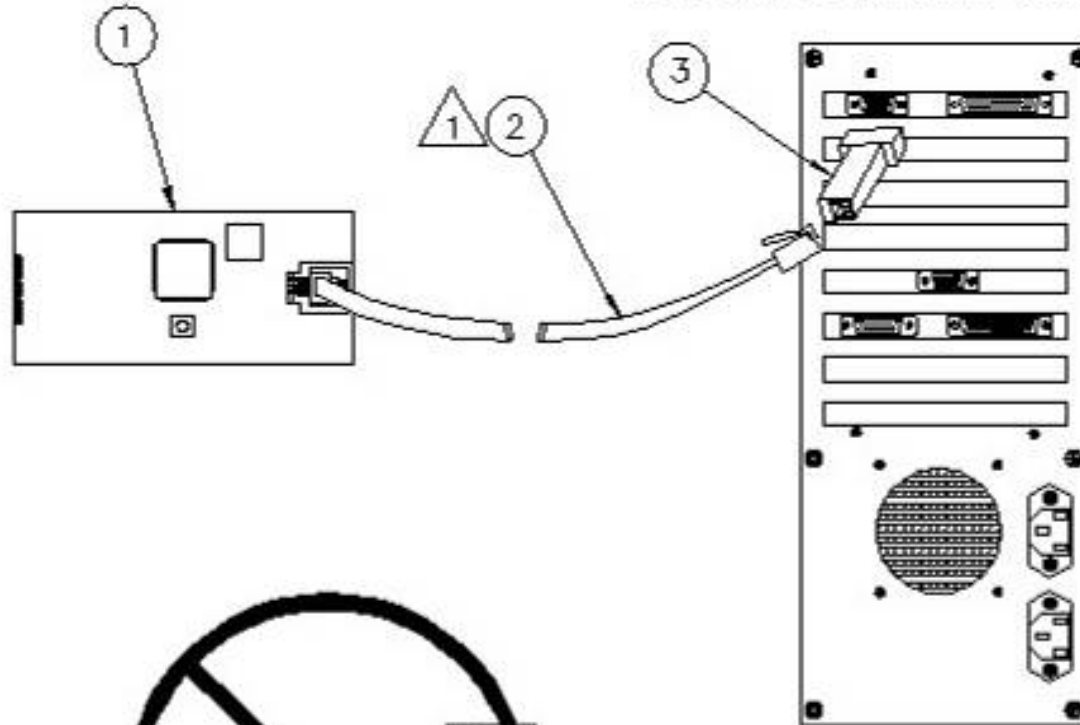

DO NOT PLUG RS232C DIRECTLY INTO TELEPHONE LINES

1	87300	ADAPTER, 9 PIN	MALE CONN TO EXT DTE	3
1	88330	CABLE, 4-STR	25 FT	2
1	RS232C	RS232C COM MODE	ASSEMBLED PCB, M-2000	1

REVISED BY		DATE	

REVISED BY		DATE	

		Lutwold INS TITUMENTS	
TITLE INSTALLATION LAYOUT		PART NO. RS232C DIRECT CONNECT TO 9 PIN, RS232C	
DRAWN BY CHECKED BY APPROVED BY TO: DIST. ONLY		PART NO. 1109700-00	

NOTES: UNLESS OTHERWISE SPECIFIED;
 1. LOADS MUST BE LESS THAN 600Ω

REVISION HISTORY						
REV	DATE	DESCRIPTION	BY	P/W	DATE	APP'D
A		RELEASE	ETW	EW	01/80	
B		REVISED	QBT	EW	10/18/87	

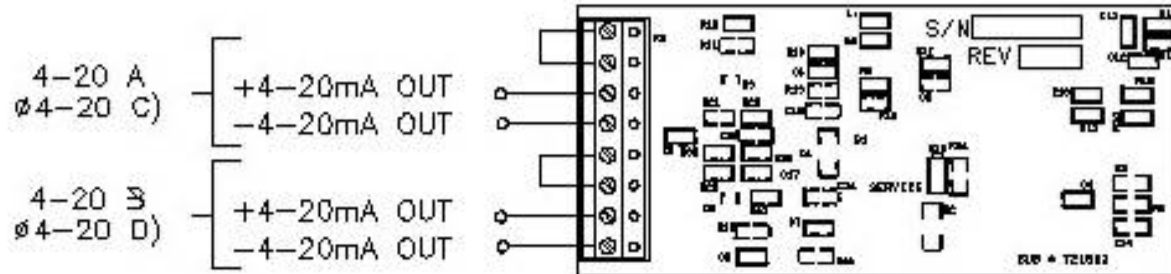

INTERNAL POWER

OPTIONAL EXTERNAL 24 VDC SUPPLY

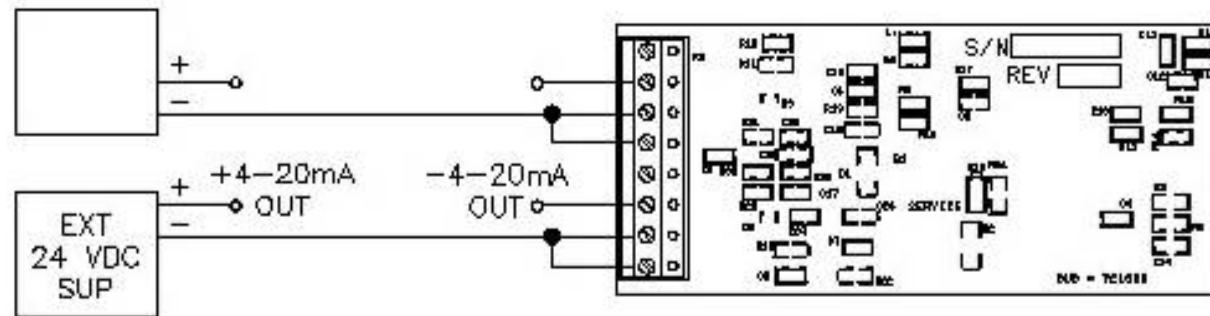

BLOCK OF IDENTIFICATION				Lakewood INSTRUMENTS	
DATE	TIME	OPERATOR	INSTR.	TEL	WIRING DIAGRAM
WORK	NO.	DATE	NO.	POWER SUPPLY, 24VDC, 4 TO 20 mA	
ORDER NO.	REV	MM	DATE	REV	1109707-1b
STARTER	END	DATE	DATE	REV	B
STARTER LOG	DATE	DATE	DATE	REV	
DO NOT SCALE	APP'D	DATE	NAME	REV	

NOTES: UNLESS OTHERWISE SPECIFIED;

1. NIN OPTION PROVIDES +24 VDC TO ALL NODES. IF USING MORE THAN 3 NODES AN EXTERNAL +24 VDC POWER SUPPLY IN PARALLEL IS RECOMMENDED.

REVISION HISTORY						
REV	ZONE	DESCRIPTION	ECO	DWN	DATE	APVD
A		RELEASE	10116	P5G	10-9-09	

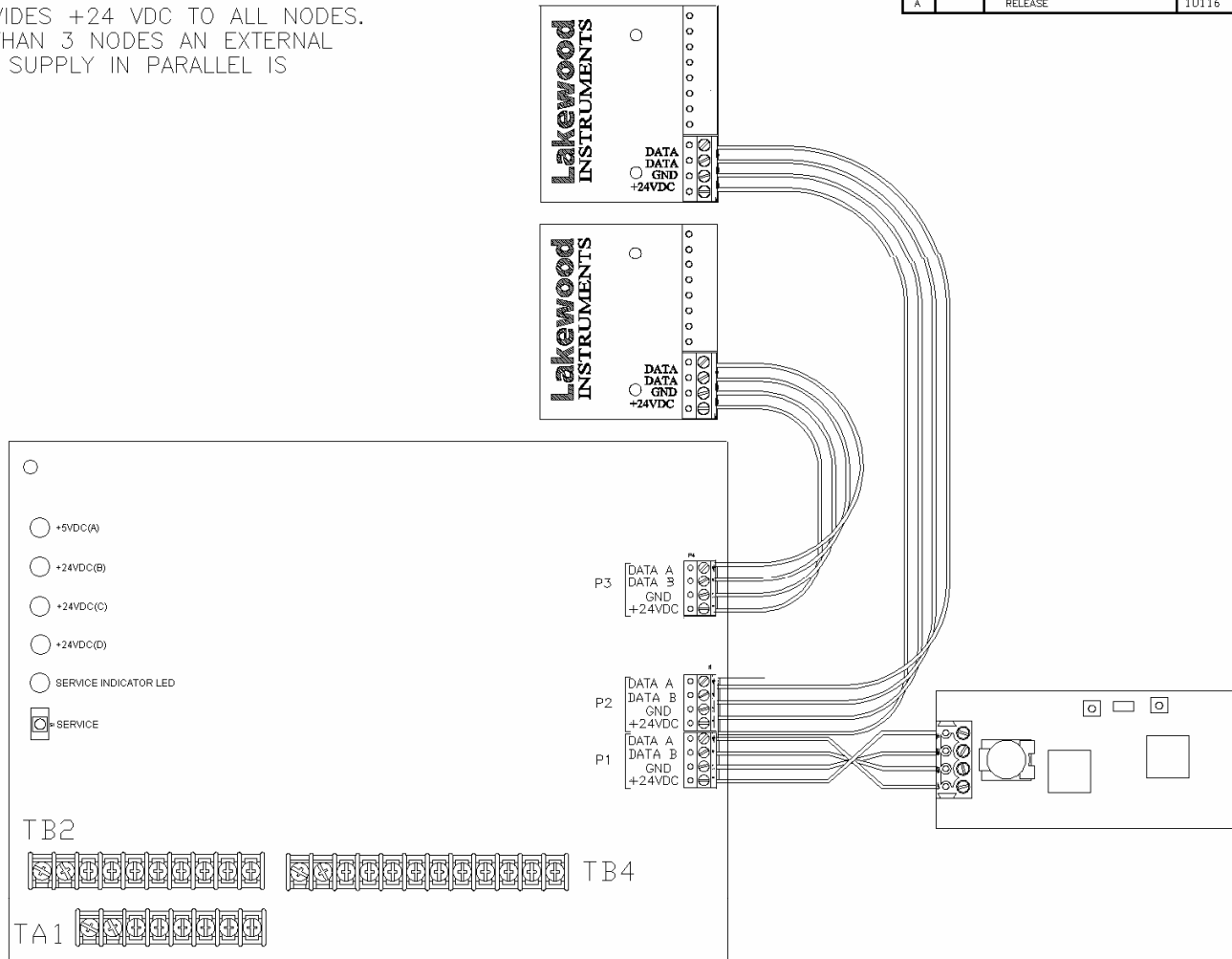

NOTICE ON REPRODUCTIONS
THIS DRAWING, THE DESIGN AND THE PATENTS IT COVERS, ARE THE PROPERTY OF LAKWOOD INC. THEY ARE LOANED MERELY AND ON THE BORROWER'S EXPRESS AGREEMENT THAT THEY WILL NOT BE REPRODUCED, COPIED, LOANED, EXHIBITED, NOR USED EXCEPT IN THE LIMITED WAY AND THE PRIVATE USE PERMITTED BY WRITTEN CONSENT GIVEN BY THE LENDER TO THE BORROWER.

MATERIAL	FRAC	DECIMALS	ANGLES
		.X ±.1	
		.XX ± .03	
	#1/16	.XXX ± .010	±.5°

ORDER NO.	DWN	PSG	DATE	10-9-09
CUSTOMER	CHKD	DATE		
CUSTOMER LOC.	APVD	DATE		
DO NOT SCALE	APVD	DATE		



TITLE
INSTALLATION DRAWING
NIN OPTION

SIZE	C	DWG NO/PN	1167855_3a	REV	A
THIS ANGLE		FILE TYPE	.DWG	SHEET 1 OF 1	

For more information call toll free in the USA (800) 228-0839

Manufactured in the USA

Lakewood Instruments

7838 North Faulkner Road, Milwaukee, WI 53224 USA

Phone (800) 228-0839 • Fax (414) 355-3508

<http://www.lakewoodinstruments.com>